

Cache-Oblivious Algorithms

MATTEO FRIGO, CHARLES E. LEISERSON, HARALD PROKOP, and
SRIDHAR RAMACHANDRAN, MIT Laboratory for Computer Science

This article presents asymptotically optimal algorithms for rectangular matrix transpose, fast Fourier transform (FFT), and sorting on computers with multiple levels of caching. Unlike previous optimal algorithms, these algorithms are *cache oblivious*: no variables dependent on hardware parameters, such as cache size and cache-line length, need to be tuned to achieve optimality. Nevertheless, these algorithms use an optimal amount of work and move data optimally among multiple levels of cache. For a cache with size \mathcal{M} and cache-line length \mathcal{B} where $\mathcal{M} = \Omega(\mathcal{B}^2)$, the number of cache misses for an $m \times n$ matrix transpose is $\Theta(1 + mn/\mathcal{B})$. The number of cache misses for either an n -point FFT or the sorting of n numbers is $\Theta(1 + (n/\mathcal{B})(1 + \log_{\mathcal{M}} n))$. We also give a $\Theta(mnp)$ -work algorithm to multiply an $m \times n$ matrix by an $n \times p$ matrix that incurs $\Theta(1 + (mn + np + mp)/\mathcal{B} + mnp/\mathcal{B}\sqrt{\mathcal{M}})$ cache faults.

We introduce an “ideal-cache” model to analyze our algorithms. We prove that an optimal cache-oblivious algorithm designed for two levels of memory is also optimal for multiple levels and that the assumption of optimal replacement in the ideal-cache model can be simulated efficiently by LRU replacement. We offer empirical evidence that cache-oblivious algorithms perform well in practice.

Categories and Subject Descriptors: F.2 [Analysis of Algorithms and Problem Complexity]: General

General Terms: Algorithms, Theory

Additional Key Words and Phrases: Algorithm, caching, cache-oblivious, fast Fourier transform, I/O complexity, matrix multiplication, matrix transpose, sorting

ACM Reference Format:

Frigo, M., Leiserson, C. E., Prokop, H., and Ramachandran, S. 2012. Cache-oblivious algorithms. *ACM Trans. Algorithms* 8, 1, Article 4 (January 2012), 22 pages.
DOI = 10.1145/2071379.2071383 <http://doi.acm.org/10.1145/2071379.2071383>

1. INTRODUCTION

Resource-oblivious algorithms that nevertheless use resources efficiently offer advantages of simplicity and portability over resource-aware algorithms whose resource usage must be programmed explicitly. In this article, we study cache resources, specifically, the hierarchy of memories in modern computers. We exhibit several “cache-oblivious” algorithms that use cache as effectively as “cache-aware” algorithms. An earlier version of this article appeared as Frigo et al. [1999].

This research was supported in part by the Defense Advance Research Projects Agency (DARPA) under Grant F30602-97-1-0270 and by the NSF under Grant CCF-0937860. M. Frigo was supported in part by a Digital Equipment Corporation fellowship. H. Prokop was supported in part by a fellowship from the Cusanuswerk, Bonn, Germany. This work was supported by the National Science Foundation under Grants CNS-0435060, CCR-0325197, and EN-CS-032609.

Authors' addresses: M. Frigo, Quanta Research Cambridge, Cambridge, MA; C. E. Leiserson, MIT Computer Science and Artificial Intelligence Laboratory, Cambridge, MA; email: cel@mit.edu; H. Prokop, Akami Technologies, Cambridge, MA; S. Ramachandran, OATSystems, Inc., Waltham, MA.

Permission to make digital or hard copies of part or all of this work for personal or classroom use is granted without fee provided that copies are not made or distributed for profit or commercial advantage and that copies show this notice on the first page or initial screen of a display along with the full citation. Copyrights for components of this work owned by others than ACM must be honored. Abstracting with credit is permitted. To copy otherwise, to republish, to post on servers, to redistribute to lists, or to use any component of this work in other works requires prior specific permission and/or a fee. Permissions may be requested from the Publications Dept., ACM, Inc., 2 Penn Plaza, Suite 701, New York, NY 10121-0701, USA, fax +1 (212) 869-0481, or permissions@acm.org.

© 2012 ACM 1549-6325/2012/01-ART4 \$10.00

DOI 10.1145/2071379.2071383 <http://doi.acm.org/10.1145/2071379.2071383>

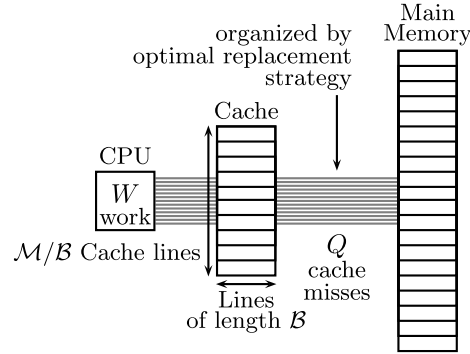

Fig. 1. The ideal-cache model.

Before discussing the notion of cache obliviousness, we first introduce the $(\mathcal{M}, \mathcal{B})$ *ideal-cache model* to study the cache complexity of algorithms. This model, which is illustrated in Figure 1, consists of a computer with a two-level memory hierarchy consisting of an ideal (data) cache of \mathcal{M} words and an arbitrarily large main memory. Because the actual size of words in a computer is typically a small, fixed size (4 bytes, 8 bytes, etc.), we shall assume that word size is constant; the particular constant does not affect our asymptotic analyses. The cache is partitioned into cache lines, each of which can store a cache block consisting of \mathcal{B} consecutive words which are always moved together between cache and main memory. Cache designers typically use $\mathcal{B} > 1$, banking on spatial locality to amortize the overhead of moving the cache block. We shall generally assume in this article that the cache is tall:

$$\mathcal{M} = \Omega(\mathcal{B}^2), \quad (1)$$

which is usually true in practice.

The processor can only reference words that reside in the cache. If the referenced word belongs to a block already in cache, a cache hit occurs, and the word is delivered to the processor. Otherwise, a cache miss occurs, and the block is fetched into the cache. The ideal cache is fully associative [Hennessy and Patterson 1996, Ch. 5]: cache blocks can be stored anywhere in the cache. If the cache is full, a cache block must be evicted. The ideal cache uses the optimal offline strategy of replacing the cache block whose next access is furthest in the future [Belady 1966], and thus it exploits temporal locality perfectly.

Unlike various other hierarchical-memory models [Aggarwal et al. 1987a, 1987b; Alpern et al. 1990; Bilardi and Peserico 2001] in which algorithms are analyzed in terms of a single measure, the ideal-cache model uses two measures. An algorithm with an input of size n is measured by its work complexity $W(n)$ —its conventional running time in a RAM model [Aho et al. 1974]—and its cache complexity $Q(n; \mathcal{M}, \mathcal{B})$ —the number of cache misses it incurs as a function of the size \mathcal{M} and line length \mathcal{B} of the ideal cache. When \mathcal{M} and \mathcal{B} are clear from context, we denote the cache complexity simply as $Q(n)$ to ease notation.

We define an algorithm to be cache aware if it contains parameters (set at either compile-time or runtime) that can be tuned to optimize the cache complexity for the particular cache size and length of cache block. Otherwise, the algorithm is cache oblivious. Historically, good performance has been obtained using cache-aware algorithms, but we shall exhibit several optimal¹ cache-oblivious algorithms.

¹For simplicity in this article, we use the term “optimal” as a synonym for “asymptotically optimal,” since all our analyses are asymptotic.

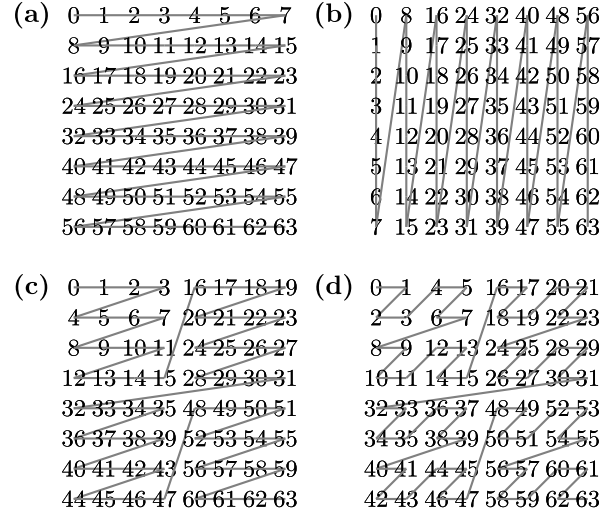

Fig. 2. Layout of a 16×16 matrix in (a) row major, (b) column major, (c) 4×4 -tiled, and (d) bit-interleaved layouts.

To illustrate the notion of cache awareness, consider the problem of multiplying two $n \times n$ matrices A and B to produce their $n \times n$ product C . We assume that the three matrices are stored in row-major order, as shown in Figure 2(a). We further assume that n is “big,” that is, $n > B$, in order to simplify the analysis. The conventional way to multiply matrices on a computer with caches is to use a tiled (or blocked) algorithm [Golub and van Loan 1989, p. 45]. The idea is to view each matrix M as consisting of $(n/s) \times (n/s)$ submatrices M_{ij} (the tiles), each of which has size $s \times s$, where s is a tuning parameter. The following algorithm implements this strategy.

ALGORITHM: TILED-MULT(A, B, C, n)

```

1 for  $i \leftarrow 1$  to  $n/s$ 
2   do for  $j \leftarrow 1$  to  $n/s$ 
3     do for  $k \leftarrow 1$  to  $n/s$ 
4       do ORD-MULT( $A_{ik}, B_{kj}, C_{ij}, s$ )

```

The ORD-MULT(A, B, C, s) subroutine computes $C \leftarrow C + AB$ on $s \times s$ matrices using the ordinary $O(s^3)$ algorithm. (This algorithm assumes for simplicity that s evenly divides n , but in practice s and n need have no special relationship, yielding more complicated code in the same spirit.)

Depending on the cache size of the machine on which TILED-MULT is run, the parameter s can be tuned to make the algorithm run fast, and thus TILED-MULT is a cache-aware algorithm. To minimize the cache complexity, we choose s to be the largest value such that the three $s \times s$ submatrices simultaneously fit in cache. An $s \times s$ submatrix is stored on $\Theta(s + s^2/B)$ cache lines. From the tall-cache assumption (1), we can see that $s = \Theta(\sqrt{M})$. Thus, each of the calls to ORD-MULT runs with at most $M/B = \Theta(s^2/B)$ cache misses needed to bring the three matrices into the cache. Consequently, the cache complexity of the entire algorithm is $\Theta(1 + n^2/B + (n/\sqrt{M})^3(M/B)) = \Theta(1 + n^2/B + n^3/B\sqrt{M})$, since the algorithm has to read n^2 elements, which reside on $\lceil n^2/B \rceil$ cache lines.

The same bound can be achieved using a simple cache-oblivious algorithm that requires no tuning parameters such as the s in BLOCK-MULT. We present such an algorithm, which works on general rectangular matrices, in Section 2. The problems of computing a matrix transpose and of performing an FFT also succumb to remarkably simple algorithms, which are described in Section 3. Cache-oblivious sorting poses a more formidable challenge. In Sections 4 and 5, we present two sorting algorithms, one based on mergesort and the other on distribution sort, both of which are optimal in both work and cache misses.

The ideal-cache model makes the perhaps-questionable assumptions that there are only two levels in the memory hierarchy, that memory is managed automatically by an optimal cache-replacement strategy, and that the cache is fully associative. We address these assumptions in Section 6, showing that to a certain extent, these assumptions entail no loss of generality. Finally, Section 8 discusses related work.

2. MATRIX MULTIPLICATION

This section describes and analyzes a cache-oblivious algorithm for multiplying an $m \times n$ matrix by an $n \times p$ matrix cache-obliviously using $\Theta(mnp)$ work and incurring $\Theta(m + n + p + (mn + np + mp)/\mathcal{B} + mnp/\mathcal{B}\sqrt{\mathcal{M}})$ cache misses. These results require the tall-cache assumption (1) for matrices stored in row-major layout format, but the assumption can be relaxed for certain other layouts. We also show that Strassen's algorithm [Strassen 1969] for multiplying $n \times n$ matrices, which uses $\Theta(n^{\lg 7})$ work,² incurs $\Theta(n + n^2/\mathcal{B} + n^{\lg 7}/\mathcal{B}\mathcal{M}^{(\lg 7)/2-1})$ cache misses.

In Blumofe et al. [1996] with others, two of the present authors analyzed an optimal divide-and-conquer algorithm for $n \times n$ matrix multiplication that contained no tuning parameters, but we did not study cache-obliviousness per se. That algorithm can be extended to multiply rectangular matrices, yielding the REC-MULT algorithm that we now describe.

REC-MULT assigns $C \leftarrow C + AB$, where A is a $m \times n$ matrix, B is a $n \times p$ matrix, and C is a $m \times p$ matrix. If C is initialized to 0 prior to the invocation of REC-MULT, the algorithm computes the matrix product of A and B .

If $m = n = p = 1$, REC-MULT performs the scalar multiply-add $C \leftarrow C + AB$. Otherwise, depending on the relative sizes of m , n , and p , we have three cases.

- (1) If $m \geq \max\{n, p\}$, we split the range of m according to the formula

$$\begin{pmatrix} C_1 \\ C_2 \end{pmatrix} = \begin{pmatrix} A_1 \\ A_2 \end{pmatrix} B = \begin{pmatrix} A_1 B \\ A_2 B \end{pmatrix}. \quad (2)$$

The algorithm recurs twice to compute $C_1 = C_1 + A_1 B$ and $C_2 = C_2 + A_2 B$.

- (2) If $n \geq \max\{m, p\}$, we split the range of n according to the formula

$$C = \begin{pmatrix} A_1 & A_2 \end{pmatrix} \begin{pmatrix} B_1 \\ B_2 \end{pmatrix} = A_1 B_1 + A_2 B_2. \quad (3)$$

Specifically, the algorithm first computes $C \leftarrow C + A_1 B_1$ recursively, and then it computes $C \leftarrow C + A_2 B_2$, also recursively. In particular, we do not allocate temporary storage for the intermediate products implied by Eq. (3).

- (3) If $p \geq \max\{m, n\}$, we split the range of p according to the formula

$$\begin{pmatrix} C_1 & C_2 \end{pmatrix} = A \begin{pmatrix} B_1 & B_2 \end{pmatrix} = \begin{pmatrix} A B_1 & A B_2 \end{pmatrix}. \quad (4)$$

²We use the notation \lg to denote \log_2 .

The algorithm recurs twice to compute $C_1 = C_1 + AB_1$ and $C_2 = C_2 + AB_2$.

If more than one case applies (e.g. if $m = n = p$), the tie can be broken arbitrarily.

Although this straightforward divide-and-conquer algorithm contains no tuning parameters, it uses cache optimally. To analyze the REC-MULT algorithm, we assume that the three matrices are stored in row-major order, as shown in Figure 2(a). Intuitively, REC-MULT uses the cache effectively, because once a subproblem fits into the cache, its smaller subproblems can be solved in cache with no further cache misses.

THEOREM 2.1. *The REC-MULT algorithm uses $\Theta(mnp)$ work and incurs $\Theta(m + n + p + (mn + np + mp)/\mathcal{B} + mnp/\mathcal{B}\sqrt{\mathcal{M}})$ cache misses when multiplying an $m \times n$ matrix by an $n \times p$ matrix.*

PROOF. It can be shown by induction that the work of REC-MULT is $\Theta(mnp)$. To analyze the cache misses, let $\alpha > 0$ be the largest constant sufficiently small that three submatrices of sizes $m' \times n'$, $n' \times p'$, and $m' \times p'$, where $\max\{m', n', p'\} \leq \alpha\sqrt{\mathcal{M}}$, all fit completely in the cache. We distinguish four cases depending on the initial size of the matrices.

Case I. $m, n, p > \alpha\sqrt{\mathcal{M}}$. This case is the most intuitive. The matrices do not fit in cache, since all dimensions are “big enough.” The cache complexity can be described by the recurrence

$$Q(m, n, p) \leq \begin{cases} \Theta((mn + np + mp)/\mathcal{B}) & \text{if } m, n, p \in [\alpha\sqrt{\mathcal{M}}/2, \alpha\sqrt{\mathcal{M}}] , \\ 2Q(m/2, n, p) + O(1) & \text{otherwise if } m \geq n \text{ and } m \geq p , \\ 2Q(m, n/2, p) + O(1) & \text{otherwise. if } n > m \text{ and } n \geq p , \\ 2Q(m, n, p/2) + O(1) & \text{otherwise .} \end{cases}$$

The base case arises as soon as all three submatrices fit in cache. The total number of lines used by the three submatrices is $\Theta((mn + np + mp)/\mathcal{B})$. The only cache misses that occur during the remainder of the recursion are the $\Theta((mn + np + mp)/\mathcal{B})$ cache misses required to bring the matrices into cache. In the recursive cases, when the matrices do not fit in cache, we pay for the cache misses of the recursive calls, which depend on the dimensions of the matrices, plus $O(1)$ cache misses for the overhead of manipulating submatrices. The solution to this recurrence is $Q(m, n, p) = \Theta(mnp/\mathcal{B}\sqrt{\mathcal{M}})$.

Case II. ($m \leq \alpha\sqrt{\mathcal{M}}$ and $n, p > \alpha\sqrt{\mathcal{M}}$) or ($n \leq \alpha\sqrt{\mathcal{M}}$ and $m, p > \alpha\sqrt{\mathcal{M}}$) or ($p \leq \alpha\sqrt{\mathcal{M}}$ and $m, n > \alpha\sqrt{\mathcal{M}}$). Here, we shall present the case where $m \leq \alpha\sqrt{\mathcal{M}}$ and $n, p > \alpha\sqrt{\mathcal{M}}$. The proofs for the other cases are only small variations of this proof. The REC-MULT algorithm always divides n or p by 2 according to Eqs. (3) and (4). At some point in the recursion, both are small enough that the whole problem fits into cache. The number of cache misses can be described by the recurrence

$$Q(m, n, p) \leq \begin{cases} \Theta(1 + n + np/\mathcal{B} + m) & \text{if } n, p \in [\alpha\sqrt{\mathcal{M}}/2, \alpha\sqrt{\mathcal{M}}] , \\ 2Q(m, n/2, p) + O(1) & \text{otherwise if } n \geq p , \\ 2Q(m, n, p/2) + O(1) & \text{otherwise ;} \end{cases} \quad (5)$$

whose solution is $Q(m, n, p) = \Theta(np/\mathcal{B} + mnp/\mathcal{B}\sqrt{\mathcal{M}})$.

Case III. ($n, p \leq \alpha\sqrt{\mathcal{M}}$ and $m > \alpha\sqrt{\mathcal{M}}$) or ($m, p \leq \alpha\sqrt{\mathcal{M}}$ and $n > \alpha\sqrt{\mathcal{M}}$) or ($m, n \leq \alpha\sqrt{\mathcal{M}}$ and $p > \alpha\sqrt{\mathcal{M}}$). In each of these cases, one of the matrices fits into cache, and the others do not. Here, we shall present the case where $n, p \leq \alpha\sqrt{\mathcal{M}}$ and $m > \alpha\sqrt{\mathcal{M}}$.

The other cases can be proved similarly. The REC-MULT algorithm always divides m by 2 according to Eq. (2). At some point in the recursion, m falls into the range $\alpha\sqrt{\mathcal{M}}/2 \leq m \leq \alpha\sqrt{\mathcal{M}}$, and the whole problem fits in cache. The number cache misses can be described by the recurrence

$$Q(m, n) \leq \begin{cases} \Theta(1 + m) & \text{if } m \in [\alpha\sqrt{\mathcal{M}}/2, \alpha\sqrt{\mathcal{M}}], \\ 2Q(m/2, n, p) + O(1) & \text{otherwise;} \end{cases} \quad (6)$$

whose solution is $Q(m, n, p) = \Theta(m + mnp/\mathcal{B}\sqrt{\mathcal{M}})$.

Case IV. $m, n, p \leq \alpha\sqrt{\mathcal{M}}$. From the choice of α , all three matrices fit into cache. The matrices are stored on $\Theta(1 + mn/\mathcal{B} + np/\mathcal{B} + mp/\mathcal{B})$ cache lines. Therefore, we have $Q(m, n, p) = \Theta(1 + (mn + np + mp)/\mathcal{B})$. \square

We require the tall-cache assumption (1) in these analyses, because the matrices are stored in row-major order. Tall caches are also needed if matrices are stored in column-major order (Figure 2(b)), but the assumption that $\mathcal{M} = \Omega(\mathcal{B}^2)$ can be relaxed for certain other matrix layouts. The $s \times s$ -tiled layout (Figure 2(c)), for some tuning parameter s , can be used to achieve the same bounds with the weaker assumption that the cache holds at least some sufficiently large constant number of cache blocks. The cache-oblivious bit-interleaved layout (Figure 2(d)) has the same advantage as the tiled layout, but no tuning parameter need be set, since submatrices of size $O(\sqrt{\mathcal{B}}) \times O(\sqrt{\mathcal{B}})$ are cache-obliviously stored on $O(1)$ cache lines. The advantages of bit-interleaved and related layouts have been studied in Chatterjee et al. [1999a, 1999b] and Frens and Wise [1997]. One of the practical disadvantages of bit-interleaved layouts is that index calculations on conventional microprocessors can be costly, a deficiency we hope that processor architects will remedy.

For square matrices, the cache complexity $Q(n) = \Theta(n + n^2/\mathcal{B} + n^3/\mathcal{B}\sqrt{\mathcal{M}})$ of the REC-MULT algorithm is the same as the cache complexity of the cache-aware BLOCK-MULT algorithm and also matches the lower bound by Hong and Kung [1981]. This lower bound holds for all algorithms that execute the $\Theta(n^3)$ operations given by the definition of matrix multiplication

$$c_{ij} = \sum_{k=1}^n a_{ik} b_{kj}.$$

No tight lower bounds for the general problem of matrix multiplication are known.

By using an asymptotically faster algorithm, such as Strassen's algorithm [Strassen 1969] or one of its variants [Winograd 1970], both the work and cache complexity can be reduced. When multiplying $n \times n$ matrices, Strassen's algorithm, which is cache oblivious, requires only 7 recursive multiplications of $n/2 \times n/2$ matrices and a constant number of matrix additions, yielding the recurrence

$$Q(n) \leq \begin{cases} \Theta(1 + n + n^2/\mathcal{B}) & \text{if } n^2 \leq \alpha\mathcal{M}, \\ 7Q(n/2) + O(n^2/\mathcal{B}) & \text{otherwise;} \end{cases} \quad (7)$$

where α is a sufficiently small constant. The solution to this recurrence is $\Theta(n + n^2/\mathcal{B} + n^{\lg 7}/\mathcal{B}\mathcal{M}^{(\lg 7)/2-1})$. A subtlety in implementing Strassen's algorithm is that the temporary matrices it requires must be stack allocated, or if they are heap allocated, storage must be reused in a stack-like fashion. An allocator that does not recycle memory can cause the algorithm to incur nearly as many "cold" cache misses as its running time, which is far from optimal.

3. MATRIX TRANSPOSITION AND FFT

This section describes a recursive cache-oblivious algorithm for transposing an $m \times n$ matrix which uses $O(mn)$ work and incurs $O(1 + mn/\mathcal{B})$ cache misses, which is optimal. Using matrix transposition as a subroutine, we convert a variant [Vitter and Shriver 1994b] of the “six-step” fast Fourier transform (FFT) algorithm [Bailey 1990] into an optimal cache-oblivious algorithm. This FFT algorithm uses $O(n \lg n)$ work and incurs $O(1 + (n/\mathcal{B})(1 + \log_{\mathcal{M}} n))$ cache misses.

The problem of matrix transposition is defined as follows. Given an $m \times n$ matrix stored in a row-major layout, compute and store A^T into an $n \times m$ matrix B also stored in a row-major layout. The straightforward algorithm for transposition that employs doubly nested loops incurs $\Theta(mn)$ cache misses on one of the matrices when $m \gg \mathcal{M}/\mathcal{B}$ and $n \gg \mathcal{M}/\mathcal{B}$, which is suboptimal.

Optimal work and cache complexities can be obtained with a divide-and-conquer strategy, however. If $n \geq m$, the REC-TRANSPOSE algorithm partitions

$$A = (A_1 \ A_2), \quad B = \begin{pmatrix} B_1 \\ B_2 \end{pmatrix}$$

and recursively executes REC-TRANSPOSE(A_1, B_1) and REC-TRANSPOSE(A_2, B_2). Otherwise, it divides matrix A horizontally and matrix B vertically and likewise performs two transpositions recursively. The next two lemmas provide upper and lower bounds on the performance of this algorithm.

LEMMA 3.1. *The REC-TRANSPOSE algorithm involves $O(mn)$ work and incurs $O(1 + mn/\mathcal{B})$ cache misses for an $m \times n$ matrix.*

PROOF. That the algorithm does $O(mn)$ work is straightforward. For the cache analysis, let $Q(m, n)$ be the cache complexity of transposing an $m \times n$ matrix. We assume that the matrices are stored in row-major order, the column-major layout having a similar analysis.

Let α be a constant sufficiently small such that two submatrices of size $m \times n$ and $n \times m$, where $\max\{m, n\} \leq \alpha\mathcal{B}$, fit completely in the cache even if each row is stored in a different cache line. We distinguish the three cases.

Case I. $\max\{m, n\} \leq \alpha\mathcal{B}$. Both the matrices fit in $O(1) + 2mn/\mathcal{B}$ lines. From the choice of α , the number of lines required is at most \mathcal{M}/\mathcal{B} . Therefore, $Q(m, n) = O(1 + mn/\mathcal{B})$.

Case II. $m \leq \alpha\mathcal{B} < n$ or $n \leq \alpha\mathcal{B} < m$. Suppose first that $m \leq \alpha\mathcal{B} < n$. The REC-TRANSPOSE algorithm divides the greater dimension n by 2 and performs divide and conquer. At some point in the recursion, n falls into the range $\alpha\mathcal{B}/2 \leq n \leq \alpha\mathcal{B}$, and the whole problem fits in cache. Because the layout is row-major, at this point the input array has n rows and m columns, and it is laid out in contiguous locations, requiring at most $O(1 + nm/\mathcal{B})$ cache misses to be read. The output array consists of nm elements in m rows, where in the worst case every row lies on a different cache line. Consequently, we incur at most $O(m + nm/\mathcal{B})$ for writing the output array. Since $n \geq \alpha\mathcal{B}/2$, the total cache complexity for this base case is $O(1 + m)$. These observations yield the recurrence

$$Q(m, n) \leq \begin{cases} O(1 + m) & \text{if } n \in [\alpha\mathcal{B}/2, \alpha\mathcal{B}] , \\ 2Q(m, n/2) + O(1) & \text{otherwise ;} \end{cases}$$

whose solution is $Q(m, n) = O(1 + mn/\mathcal{B})$.

The case $n \leq \alpha\mathcal{B} < m$ is analogous.

Case III. $m, n > \alpha\mathcal{B}$. As in Case II, at some point in the recursion both n and m fall into the range $[\alpha\mathcal{B}/2, \alpha\mathcal{B}]$. The whole problem fits into cache and can be solved with at most $O(m+n+mn/\mathcal{B})$ cache misses. The cache complexity thus satisfies the recurrence

$$Q(m, n) \leq \begin{cases} O(m+n+mn/\mathcal{B}) & \text{if } m, n \in [\alpha\mathcal{B}/2, \alpha\mathcal{B}] , \\ 2Q(m/2, n) + O(1) & \text{if } m \geq n , \\ 2Q(m, n/2) + O(1) & \text{otherwise;} \end{cases} \quad (8)$$

whose solution is $Q(m, n) = O(1+mn/\mathcal{B})$. \square

THEOREM 3.2. *The REC-TRANSPOSE algorithm exhibits optimal cache complexity.*

PROOF. For an $m \times n$ matrix, the algorithm must write to mn distinct elements, which occupy at least $\lceil mn/\mathcal{B} \rceil = \Omega(1+mn/\mathcal{B})$ cache lines. \square

As an example of an application of this cache-oblivious transposition algorithm, in the rest of this section we describe and analyze a cache-oblivious algorithm for computing the discrete Fourier transform of a complex array of n elements, where n is an exact power of 2. The basic algorithm is the well-known “six-step” variant [Bailey 1990; Vitter and Shriver 1994b] of the Cooley-Tukey FFT algorithm [Cooley and Tukey 1965]. Using the cache-oblivious transposition algorithm, however, the FFT becomes cache-oblivious, and its performance matches the lower bound by Hong and Kung [1981].

Recall that the discrete Fourier transform (DFT) of an array X of n complex numbers is the array Y given by

$$Y[i] = \sum_{j=0}^{n-1} X[j] \omega_n^{-ij} , \quad (9)$$

where $\omega_n = e^{2\pi\sqrt{-1}/n}$ is a primitive n th root of unity, and $0 \leq i < n$. Many algorithms evaluate Eq. (9) in $O(n \lg n)$ time for all integers n [Duhamel and Vetterli 1990]. In this article, however, we assume that n is an exact power of 2, and we compute Eq. (9) according to the Cooley-Tukey algorithm, which works recursively as follows. In the base case where $n = O(1)$, we compute Eq. (9) directly. Otherwise, for any factorization $n = n_1 n_2$ of n , we have

$$Y[i_1 + i_2 n_1] = \sum_{j_2=0}^{n_2-1} \left(\left(\sum_{j_1=0}^{n_1-1} X[j_1 n_2 + j_2] \omega_{n_1}^{-i_1 j_1} \right) \omega_n^{-i_1 j_2} \right) \omega_{n_2}^{-i_2 j_2} . \quad (10)$$

Observe that both the inner and outer summations in Eq. (10) are DFT's. Operationally, the computation specified by Eq. (10) can be performed by computing n_2 transforms of size n_1 (the inner sum), multiplying the result by the factors $\omega_n^{-i_1 j_2}$ (called the twiddle factors [Duhamel and Vetterli 1990]), and finally computing n_1 transforms of size n_2 (the outer sum).

We choose n_1 to be $2^{\lceil \lg n/2 \rceil}$ and n_2 to be $2^{\lfloor \lg n/2 \rfloor}$. The recursive step then operates as follows.

- (1) Pretend that input is a row-major $n_1 \times n_2$ matrix A . Transpose A in place, that is, use the cache-oblivious REC-TRANSPOSE algorithm to transpose A onto an auxiliary array B , and copy B back onto A . Notice that if $n_1 = 2n_2$, we can consider the matrix to be made up of records containing two elements.

- (2) At this stage, the inner sum corresponds to a DFT of the n_2 rows of the transposed matrix. Compute these n_2 DFT's of size n_1 recursively. Observe that, because of the previous transposition, we are transforming a contiguous array of elements.
- (3) Multiply A by the twiddle factors, which can be computed on the fly with no extra cache misses.
- (4) Transpose A in place, so that the inputs to the next stage are arranged in contiguous locations.
- (5) Compute n_1 DFT's of the rows of the matrix recursively.
- (6) Transpose A in place so as to produce the correct output order.

It can be proved by induction that the work complexity of this FFT algorithm is $O(n \lg n)$. We now analyze its cache complexity. The algorithm always operates on contiguous data, by construction. Thus, by the tall-cache assumption (1), the transposition operations and the twiddle-factor multiplication require at most $O(1 + n/B)$ cache misses. Thus, the cache complexity satisfies the recurrence

$$Q(n) \leq \begin{cases} O(1 + n/B), & \text{if } n \leq \alpha\mathcal{M}, \\ n_1 Q(n_2) + n_2 Q(n_1) + O(1 + n/B) & \text{otherwise;} \end{cases} \quad (11)$$

where $\alpha > 0$ is a constant sufficiently small that a subproblem of size $\alpha\mathcal{M}$ fits in cache. This recurrence has solution

$$Q(n) = O\left(1 + (n/B)(1 + \log_{\mathcal{M}} n)\right),$$

which is optimal for a Cooley-Tukey algorithm, matching the lower bound by Hong and Kung [1981] when n is an exact power of 2. As with matrix multiplication, no tight lower bounds for cache complexity are known for the general DFT problem.

4. FUNNELSORT

Existing cache-oblivious sorting algorithms, for example the familiar two-way merge sort, are not optimal with respect to cache misses. The \mathcal{M} -way mergesort suggested by Aggarwal and Vitter [1988] has optimal cache complexity, but although it apparently works well in practice [LaMarca and Ladner 1997], it is cache aware. This section describes a cache-oblivious sorting algorithm called “funnelsort.” This algorithm has optimal $O(n \lg n)$ work complexity, and optimal $O(1 + (n/B)(1 + \log_{\mathcal{M}} n))$ cache complexity.

Funnelsort is similar to mergesort. In order to sort a (contiguous) array of n elements, funnelsort performs the following two steps.

- (1) Split the input into $n^{1/3}$ contiguous arrays of size $n^{2/3}$, and sort these arrays recursively.
- (2) Merge the $n^{1/3}$ sorted sequences using a $n^{1/3}$ -merger, which is described in this section.

Funnelsort differs from mergesort in the way the merge operation works. Merging is performed by a device called a k -merger, which inputs k sorted sequences and merges them. A k -merger operates by recursively merging sorted sequences that become progressively longer as the algorithm proceeds. Unlike mergesort, however, a k -merger suspends work on a merging subproblem when the merged output sequence becomes “long enough” and resumes work on another merging subproblem.

This complicated flow of control makes a k -merger a bit tricky to describe. Figure 3 shows a representation of a k -merger, which has k sorted sequences as inputs. Throughout its execution, the k -merger maintains the following invariant.

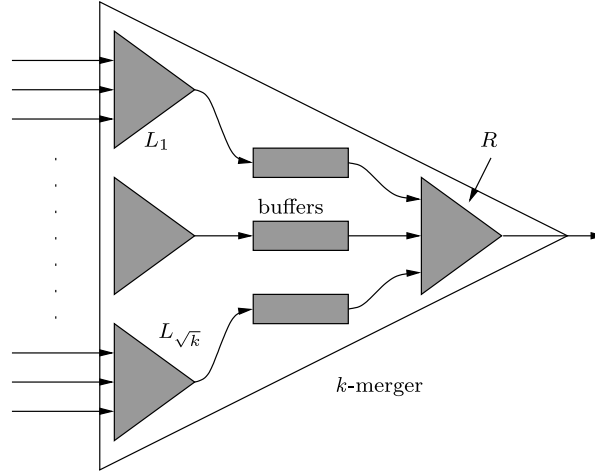

Fig. 3. Illustration of a k -merger. A k -merger is built recursively out of \sqrt{k} “left” \sqrt{k} -mergers $L_1, L_2, \dots, L_{\sqrt{k}}$, a series of buffers, and one “right” \sqrt{k} -merger R .

Invariant. Each invocation of a k -merger outputs the next k^3 elements of the sorted sequence obtained by merging the k input sequences.

A k -merger is built recursively out of \sqrt{k} -mergers in the following way. The k inputs are partitioned into \sqrt{k} sets of \sqrt{k} elements, which form the input to the \sqrt{k} \sqrt{k} -mergers $L_1, L_2, \dots, L_{\sqrt{k}}$ in the left part of the figure. The outputs of these mergers are connected to the inputs of \sqrt{k} buffers. Each buffer is a FIFO queue that can hold $2k^{3/2}$ elements. Finally, the outputs of the buffers are connected to the \sqrt{k} inputs of the \sqrt{k} -merger R in the right part of the figure. The output of this final \sqrt{k} -merger becomes the output of the whole k -merger. The intermediate buffers are overdimensioned, since each can hold $2k^{3/2}$ elements, which is twice the number $k^{3/2}$ of elements output by a \sqrt{k} -merger. This additional buffer space is necessary for the correct behavior of the algorithm, as will be explained below. The base case of the recursion is a k -merger with $k = 2$, which produces $k^3 = 8$ elements whenever invoked.

A k -merger operates recursively in the following way. In order to output k^3 elements, the k -merger invokes R $k^{3/2}$ times. Before each invocation, however, the k -merger fills all buffers that are less than half full, that is, all buffers that contain less than $k^{3/2}$ elements. In order to fill buffer i , the algorithm invokes the corresponding left merger L_i once. Since L_i outputs $k^{3/2}$ elements, the buffer contains at least $k^{3/2}$ elements after L_i finishes.

It can be proven by induction that the work complexity of funnelsort is $O(n \lg n)$. We will now analyze the cache complexity. The goal of the analysis is to show that funnelsort on n elements requires at most $Q(n)$ cache misses, where

$$Q(n) = O(1 + (n/B)(1 + \log_{\mathcal{M}} n)) .$$

In order to prove this result, we need three auxiliary lemmas. The first lemma bounds the space required by a k -merger.

LEMMA 4.1. *A k -merger can be laid out in $O(k^2)$ contiguous memory locations.*

PROOF. A k -merger requires $O(k^2)$ memory locations for the buffers, plus the space required by the \sqrt{k} -mergers. The space $S(k)$ thus satisfies the recurrence

$$S(k) \leq (\sqrt{k} + 1)S(\sqrt{k}) + O(k^2),$$

whose solution is $S(k) = O(k^2)$. \square

In order to achieve the bound on $Q(n)$, the buffers in a k -merger must be maintained as circular queues of size k . This requirement guarantees that we can manage the queue cache-efficiently, in the sense stated by the next lemma.

LEMMA 4.2. *Performing r insert and remove operations on a circular queue causes in $O(1 + r/B)$ cache misses as long as two cache lines are available for the buffer.*

PROOF. Associate the two cache lines with the head and tail of the circular queue. If a new cache block is read during an insert (delete) operation, the next $B - 1$ insert (delete) operations do not cause a cache miss. \square

The next lemma bounds the cache complexity of a k -merger.

LEMMA 4.3. *If $\mathcal{M} = \Omega(B^2)$, then a k -merger operates with at most*

$$Q_{\text{merge}}(k) = O(1 + k + k^3/B + (k^3 \log_{\mathcal{M}} k)/B)$$

cache misses.

PROOF. There are two cases: either $k < \alpha\sqrt{\mathcal{M}}$ or $k > \alpha\sqrt{\mathcal{M}}$, where α is a sufficiently small constant.

Case I. $k < \alpha\sqrt{\mathcal{M}}$. By Lemma 4.1, the data structure associated with the k -merger requires at most $O(k^2) = O(\mathcal{M})$ contiguous memory locations, and therefore it fits into cache. The k -merger has k input queues from which it loads $O(k^3)$ elements. Let r_i be the number of elements extracted from the i th input queue. Since $k < \alpha\sqrt{\mathcal{M}}$ and the tall-cache assumption (1) implies that $B = O(\sqrt{\mathcal{M}})$, there are at least $\mathcal{M}/B = \Omega(k)$ cache lines available for the input buffers. Lemma 4.2 applies, whence the total number of cache misses for accessing the input queues is

$$\sum_{i=1}^k O(1 + r_i/B) = O(k + k^3/B).$$

Similarly, Lemma 4.1 implies that the cache complexity of writing the output queue is $O(1 + k^3/B)$. Finally, the algorithm incurs $O(1 + k^2/B)$ cache misses for touching its internal data structures. The total cache complexity is therefore $Q_{\text{merge}}(k) = O(1 + k + k^3/B)$.

Case I. $k > \alpha\sqrt{\mathcal{M}}$. We prove by induction on k that whenever $k > \alpha\sqrt{\mathcal{M}}$, we have

$$Q_{\text{merge}}(k) \leq ck^3 \log_{\mathcal{M}} k/B - A(k), \quad (12)$$

where $A(k) = k(1 + (2c \log_{\mathcal{M}} k)/B) = o(k^3)$. This particular value of $A(k)$ will be justified at the end of the analysis.

The base case of the induction consists of values of k such that $\alpha\mathcal{M}^{1/4} < k < \alpha\sqrt{\mathcal{M}}$. (It is not sufficient only to consider $k = \Theta(\sqrt{\mathcal{M}})$, since k can become as small as $\Theta(\mathcal{M}^{1/4})$ in the recursive calls.) The analysis of the first case applies, yielding $Q_{\text{merge}}(k) = O(1 + k + k^3/B)$. Because $k^2 > \alpha\sqrt{\mathcal{M}} = \Omega(B)$ and $k = \Omega(1)$, the last term dominates, which implies $Q_{\text{merge}}(k) = O(k^3/B)$. Consequently, a big enough value of c can be found that satisfies Inequality (12).

For the inductive case, suppose that $k > \alpha\sqrt{\mathcal{M}}$. The k -merger invokes the \sqrt{k} -mergers recursively. Since $\alpha\mathcal{M}^{1/4} < \sqrt{k} < k$, the inductive hypothesis can be used to bound the number $Q_{\text{merge}}(\sqrt{k})$ of cache misses incurred by the submergers. The “right” merger R is invoked exactly $k^{3/2}$ times. The total number l of invocations of “left” mergers is bounded by $l < k^{3/2} + 2\sqrt{k}$. To see why, consider that every invocation of a left merger puts $k^{3/2}$ elements into some buffer. Since k^3 elements are output and the buffer space is $2k^2$, the bound $l < k^{3/2} + 2\sqrt{k}$ follows.

Before invoking R , the algorithm must check every buffer to see whether it is empty. One such check requires at most \sqrt{k} cache misses, since there are \sqrt{k} buffers. This check is repeated exactly $k^{3/2}$ times, leading to at most k^2 cache misses for all checks. These considerations lead to the recurrence

$$Q_{\text{merge}}(k) \leq \left(2k^{3/2} + 2\sqrt{k}\right) Q_{\text{merge}}(\sqrt{k}) + k^2 .$$

Application of the inductive hypothesis and the choice $A(k) = k(1 + (2c \log_{\mathcal{M}} k)/\mathcal{B})$ yields Inequality (12) as follows:

$$\begin{aligned} Q_{\text{merge}}(k) &\leq \left(2k^{3/2} + 2\sqrt{k}\right) Q_{\text{merge}}(\sqrt{k}) + k^2 \\ &\leq 2 \left(k^{3/2} + \sqrt{k}\right) \left(\frac{ck^{3/2} \log_{\mathcal{M}} k}{2\mathcal{B}} - A(\sqrt{k})\right) + k^2 \\ &\leq (ck^3 \log_{\mathcal{M}} k)/\mathcal{B} + k^2 \left(1 + (c \log_{\mathcal{M}} k)/\mathcal{B}\right) - \left(2k^{3/2} + 2\sqrt{k}\right) A(\sqrt{k}) \\ &\leq (ck^3 \log_{\mathcal{M}} k)/\mathcal{B} - A(k) . \end{aligned} \quad \square$$

THEOREM 4.4. *To sort n elements, funnelsort incurs $O(1 + (n/\mathcal{B})(1 + \log_{\mathcal{M}} n))$ cache misses.*

PROOF. If $n < \alpha\mathcal{M}$ for a small enough constant α , then the algorithm fits into cache. To see why, observe that only one k -merger is active at any time. The biggest k -merger is the top-level $n^{1/3}$ -merger, which requires $O(n^{2/3}) < O(n)$ space. The algorithm thus can operate in $O(1 + n/\mathcal{B})$ cache misses.

If $N > \alpha\mathcal{M}$, we have the recurrence

$$Q(n) = n^{1/3} Q(n^{2/3}) + Q_{\text{merge}}(n^{1/3}) .$$

By Lemma 4.3, we have $Q_{\text{merge}}(n^{1/3}) = O(1 + n^{1/3} + n/\mathcal{B} + (n \log_{\mathcal{M}} n)/\mathcal{B})$.

By the tall-cache assumption (1), we have $n/\mathcal{B} = \Omega(n^{1/3})$. Moreover, we also have $n^{1/3} = \Omega(1)$ and $\lg n = \Omega(\lg \mathcal{M})$. Consequently, $Q_{\text{merge}}(n^{1/3}) = O((n \log_{\mathcal{M}} n)/\mathcal{B})$ holds, and the recurrence simplifies to

$$Q(n) = n^{1/3} Q(n^{2/3}) + O((n \log_{\mathcal{M}} n)/\mathcal{B}) .$$

The result follows by induction on n . □

This upper bound matches the lower bound stated by the next theorem, proving that funnelsort is cache-optimal.

THEOREM 4.5. *The cache complexity of any sorting algorithm is $Q(n) = \Omega(1 + (n/\mathcal{B})(1 + \log_{\mathcal{M}} n))$.*

PROOF. Aggarwal and Vitter [1988] show that there is an $\Omega((n/B) \log_{\mathcal{M}/B}(n/\mathcal{M}))$ bound on the number of cache misses made by any sorting algorithm on their “out-of-core” memory model, a bound that extends to the ideal-cache model. The theorem can be proved by applying the tall-cache assumption $\mathcal{M} = \Omega(B^2)$ and the trivial lower bounds of $Q(n) = \Omega(1)$ and $Q(n) = \Omega(n/B)$. \square

5. DISTRIBUTION SORT

In this section, we describe another cache-oblivious optimal sorting algorithm based on distribution sort. Like the funnel-sort algorithm from Section 4, the distribution-sorting algorithm uses $O(n \lg n)$ work to sort n elements, and it incurs $O(1 + (n/B)(1 + \log_{\mathcal{M}} n))$ cache misses. Unlike previous cache-efficient distribution-sorting algorithms [Aggarwal and Vitter 1988; Aggarwal et al. 1987a; Nodine and Vitter 1993; Vitter and Nodine 1993; Vitter and Shriver 1994b], which use sampling or other techniques to find the partitioning elements before the distribution step, our algorithm uses a “bucket splitting” technique to select pivots incrementally during the distribution step.

Given an array A (stored in contiguous locations) of length n , the cache-oblivious distribution sort operates as follows.

- (1) Partition A into \sqrt{n} contiguous subarrays of size \sqrt{n} . Recursively sort each subarray.
- (2) Distribute the sorted subarrays into q buckets B_1, \dots, B_q of size n_1, \dots, n_q , respectively, such that
 - (a) $\max \{x \mid x \in B_i\} \leq \min \{x \mid x \in B_{i+1}\}$ for $i = 1, 2, \dots, q - 1$.
 - (b) $n_i \leq 2\sqrt{n}$ for $i = 1, 2, \dots, q$.
 (See below for details.)
- (3) Recursively sort each bucket.
- (4) Copy the sorted buckets to array A .

A stack-based memory allocator is used to exploit spatial locality.

The goal of Step (2) is to distribute the sorted subarrays of A into q buckets B_1, B_2, \dots, B_q . The algorithm maintains two invariants. First, at any time each bucket holds at most $2\sqrt{n}$ elements, and any element in bucket B_i is smaller than any element in bucket B_{i+1} . Second, every bucket has an associated pivot. Initially, only one empty bucket exists with pivot ∞ .

The idea is to copy all elements from the subarrays into the buckets while maintaining the invariants. We keep state information for each subarray and bucket. The state of a subarray consists of the index *next* of the next element to be read from the subarray and the bucket number *bnum* where this element should be copied. By convention, *bnum* = ∞ if all elements in a subarray have been copied. The state of a bucket consists of the pivot and the number of elements currently in the bucket.

We would like to copy the element at position *next* of a subarray to bucket *bnum*. If this element is greater than the pivot of bucket *bnum*, we would increment *bnum* until we find a bucket for which the element is smaller than the pivot. Unfortunately, this basic strategy has poor caching behavior, which calls for a more complicated procedure.

The distribution step is accomplished by the recursive procedure `DISTRIBUTE(i, j, m)` which distributes elements from the i th through $(i + m - 1)$ th subarrays into buckets starting from B_j . Given the precondition that each subarray $i, i + 1, \dots, i + m - 1$ has its *bnum* $\geq j$, the execution of `DISTRIBUTE(i, j, m)` enforces the postcondition that subarrays $i, i + 1, \dots, i + m - 1$ have their *bnum* $\geq j + m$. Step 2

of the distribution sort invokes $\text{DISTRIBUTE}(1, 1, \sqrt{n})$. The following is a recursive implementation of DISTRIBUTE :

ALGORITHM: $\text{DISTRIBUTE}(i, j, m)$

```

1  if  $m = 1$ 
2    then  $\text{COPYElems}(i, j)$ 
3    else  $\text{DISTRIBUTE}(i, j, m/2)$ 
4           $\text{DISTRIBUTE}(i + m/2, j, m/2)$ 
5           $\text{DISTRIBUTE}(i, j + m/2, m/2)$ 
6           $\text{DISTRIBUTE}(i + m/2, j + m/2, m/2)$ 

```

In the base case, the procedure $\text{COPYElems}(i, j)$ copies all elements from subarray i that belong to bucket j . If bucket j has more than $2\sqrt{n}$ elements after the insertion, it can be split into two buckets of size at least \sqrt{n} . For the splitting operation, we use the deterministic median-finding algorithm [Cormen et al. 1990, p. 189] followed by a partition.

LEMMA 5.1. *The median of n elements can be found cache-obliviously using $O(n)$ work and incurring $O(1 + n/B)$ cache misses.*

PROOF. See Cormen et al. [1990, p. 189] for the linear-time median finding algorithm and the work analysis. The cache complexity is given by the same recurrence as the work complexity with a different base case.

$$Q(m) = \begin{cases} O(1 + m/B) & \text{if } m \leq \alpha M, \\ Q(\lceil m/5 \rceil) + Q(7m/10 + 6) + O(1 + m/B) & \text{otherwise;} \end{cases}$$

where α is a sufficiently small constant. The result follows. \square

In our case, we have buckets of size $2\sqrt{n} + 1$. In addition, when a bucket splits, all subarrays whose $bnum$ is greater than the $bnum$ of the split bucket must have their $bnum$'s incremented. The analysis of DISTRIBUTE is given by the following lemma.

LEMMA 5.2. *The distribution step involves $O(n)$ work, incurs $O(1 + n/B)$ cache misses, and uses $O(n)$ stack space to distribute n elements.*

PROOF. In order to simplify the analysis of the work used by DISTRIBUTE , assume that COPYElems uses $O(1)$ work for procedural overhead. We will account for the work due to copying elements and splitting of buckets separately. The work of DISTRIBUTE is described by the recurrence

$$T(c) = 4T(c/2) + O(1).$$

It follows that $T(c) = O(c^2)$, where $c = \sqrt{n}$ initially. The work due to copying elements is also $O(n)$.

The total number of bucket splits is at most \sqrt{n} . To see why, observe that there are at most \sqrt{n} buckets at the end of the distribution step, since each bucket contains at least \sqrt{n} elements. Each split operation involves $O(\sqrt{n})$ work and so the net contribution to the work is $O(n)$. Thus, the total work used by DISTRIBUTE is $W(n) = O(T(\sqrt{n})) + O(n) + O(n) = O(n)$.

For the cache analysis, we distinguish two cases. Let α be a sufficiently small constant such that the stack space used fits into cache.

Case I. $n \leq \alpha\mathcal{M}$. The input and the auxiliary space of size $O(n)$ fit into cache using $O(1 + n/\mathcal{B})$ cache lines. Consequently, the cache complexity is $O(1 + n/\mathcal{B})$.

Case II. $n > \alpha\mathcal{M}$. Let $R(c, m)$ denote the cache misses incurred by an invocation of $\text{DISTRIBUTE}(a, b, c)$ that copies m elements from subarrays to buckets. We first prove that $R(c, m) = O(\mathcal{B} + c^2/\mathcal{B} + m/\mathcal{B})$, ignoring the cost splitting of buckets, which we shall account for separately. We argue that $R(c, m)$ satisfies the recurrence

$$R(c, m) \leq \begin{cases} O(\mathcal{B} + m/\mathcal{B}) & \text{if } c \leq \alpha\mathcal{B} , \\ \sum_{i=1}^4 R(c/2, m_i) & \text{otherwise ;} \end{cases} \quad (13)$$

where $\sum_{i=1}^4 m_i = m$, whose solution is $R(c, m) = O(\mathcal{B} + c^2/\mathcal{B} + m/\mathcal{B})$. The recursive case $c > \alpha\mathcal{B}$ follows immediately from the algorithm. The base case $c \leq \alpha\mathcal{B}$ can be justified as follows. An invocation of $\text{DISTRIBUTE}(a, b, c)$ operates with c subarrays and c buckets. Since there are $\Omega(\mathcal{B})$ cache lines, the cache can hold all the auxiliary storage involved and the currently accessed element in each subarray and bucket. In this case, there are $O(\mathcal{B} + m/\mathcal{B})$ cache misses. The initial access to each subarray and bucket causes $O(c) = O(\mathcal{B})$ cache misses. Copying the m elements to and from contiguous locations causes $O(1 + m/\mathcal{B})$ cache misses.

We still need to account for the cache misses caused by the splitting of buckets. Each split causes $O(1 + \sqrt{n}/\mathcal{B})$ cache misses due to median finding (Lemma 5.1) and partitioning of \sqrt{n} contiguous elements. An additional $O(1 + \sqrt{n}/\mathcal{B})$ misses are incurred by restoring the cache. As proved in the work analysis, there are at most \sqrt{n} split operations. By adding $R(\sqrt{n}, n)$ to the split complexity, we conclude that the total cache complexity of the distribution step is $O(\mathcal{B} + n/\mathcal{B} + \sqrt{n}(1 + \sqrt{n}/\mathcal{B})) = O(n/\mathcal{B})$. \square

The analysis of distribution sort is given in the next theorem. The work and cache complexity match lower bounds specified in Theorem 4.5.

THEOREM 5.3. *Distribution sort uses $O(n \lg n)$ work and incurs $O(1 + (n/\mathcal{B})(1 + \log_{\mathcal{M}} n))$ cache misses to sort n elements.*

PROOF. The work done by the algorithm is given by

$$W(n) = \sqrt{n}W(\sqrt{n}) + \sum_{i=1}^q W(n_i) + O(n) ,$$

where each $n_i \leq 2\sqrt{n}$ and $\sum n_i = n$. The solution to this recurrence is $W(n) = O(n \lg n)$.

The space complexity of the algorithm is given by

$$S(n) \leq S(2\sqrt{n}) + O(n) ,$$

where the $O(n)$ term comes from Step 2. The solution to this recurrence is $S(n) = O(n)$.

The cache complexity of distribution sort is described by the recurrence

$$Q(n) \leq \begin{cases} O(1 + n/\mathcal{B}) & \text{if } n \leq \alpha\mathcal{M} , \\ \sqrt{n}Q(\sqrt{n}) + \sum_{i=1}^q Q(n_i) + O(1 + n/\mathcal{B}) & \text{otherwise ;} \end{cases}$$

where α is a sufficiently small constant such that the stack space used by a sorting problem of size $\alpha\mathcal{M}$, including the input array, fits completely in cache. The base case $n \leq \alpha\mathcal{M}$ arises when both the input array A and the contiguous stack space of size

$S(n) = O(n)$ fit in $O(1 + n/B)$ cache lines of the cache. In this case, the algorithm incurs $O(1 + n/B)$ cache misses to touch all involved memory locations once. In the case where $n > \alpha M$, the recursive calls in Steps 1 and 3 cause $Q(\sqrt{n}) + \sum_{i=1}^q Q(n_i)$ cache misses and $O(1 + n/B)$ is the cache complexity of Steps 2 and 4, as shown by Lemma 5.2. The theorem follows by solving the recurrence. \square

6. THEORETICAL JUSTIFICATIONS FOR THE IDEAL-CACHE MODEL

How reasonable is the ideal-cache model for algorithm design? The model incorporates four major assumptions that deserve scrutiny:

- optimal replacement,
- exactly two levels of memory,
- automatic replacement,
- full associativity.

Designing algorithms in the ideal-cache model is easier than in models lacking these properties, but are these assumptions too strong? In this section, we show that cache-oblivious algorithms designed in the ideal-cache model can be efficiently simulated by weaker models.

The first assumption that we shall eliminate is that of optimal replacement. Our strategy for the simulation is to use an LRU (least-recently used) replacement strategy [Hennessy and Patterson 1996, p. 378] in place of the optimal and omniscient replacement strategy. We start by proving a lemma that bounds the effectiveness of the LRU simulation. We then show that algorithms whose complexity bounds satisfy a simple regularity condition (including all algorithms heretofore presented) can be ported to caches incorporating an LRU replacement policy.

LEMMA 6.1. *Consider an algorithm that causes $Q^*(n; M, B)$ cache misses on a problem of size n using a (M, B) ideal cache. Then, the same algorithm incurs $Q(n; M, B) \leq 2Q^*(n; M/2, B)$ cache misses on a (M, B) cache that uses LRU replacement.*

PROOF. Sleator and Tarjan [1985] have shown that the cache misses on a (M, B) cache using LRU replacement are $(M/B)/((M - M^*)/B + 1)$ -competitive with optimal replacement on a (M^*, B) ideal cache if both caches start empty. It follows that the number of misses on a (M, B) LRU-cache is at most twice the number of misses on a $(M/2, B)$ ideal-cache. \square

COROLLARY 6.2. *For any algorithm whose cache-complexity bound $Q(n; M, B)$ in the ideal-cache model satisfies the regularity condition*

$$Q(n; M, B) = O(Q(n; 2M, B)), \quad (14)$$

the number of cache misses with LRU replacement is $\Theta(Q(n; M, B))$.

PROOF. Follows directly from (14) and Lemma 6.1. \square

The second assumption we shall eliminate is the assumption of only two levels of memory. Although models incorporating multiple levels of caches may be necessary to analyze some algorithms, for cache-oblivious algorithms, analysis in the two-level ideal-cache model suffices. Specifically, optimal cache-oblivious algorithms also perform optimally in computers with multiple levels of LRU caches. We assume that the caches satisfy the inclusion property [Hennessy and Patterson 1996, p. 723], which says that the values stored in cache i are also stored in cache $i + 1$ (where cache 1 is the cache closest to the processor). We also assume that if two elements belong to the same cache line at level i , then they belong to the same line at level $i + 1$. Moreover, we assume that cache $i + 1$ has strictly more cache lines than cache i . These assumptions

ensure that cache $i + 1$ includes the contents of cache i plus at least one more cache line.

The multilevel LRU cache operates as follows. A hit on an element in cache i is served by cache i and is not seen by higher-level caches. We consider a line in cache $i + 1$ to be marked if any element stored on the line belongs to cache i . When cache i misses on an access, it recursively fetches the needed block from cache $i + 1$, replacing the least-recently accessed unmarked cache line. The replaced cache line is then brought to the front of cache $(i + 1)$'s LRU list. Because marked cache lines are never replaced, the multilevel cache maintains the inclusion property. The next lemma asserts that even though a cache in a multilevel model does not see accesses that hit at lower levels, it nevertheless behaves like the first-level cache of a simple two-level model, which sees all the memory accesses.

LEMMA 6.3. *A $(\mathcal{M}_i, \mathcal{B}_i)$ -cache at a given level i of a multilevel LRU model always contains the same cache blocks as a simple $(\mathcal{M}_i, \mathcal{B}_i)$ -cache managed by LRU that serves the same sequence of memory accesses.* \square

We prove this lemma by induction on the cache level. Cache 1 trivially satisfies the above lemma. Now, we can assume that cache i satisfies Lemma 6.3.

Assume that the contents of cache i (say A) and hypothetical cache (say B) are the same up to access h . If access $h + 1$ is a cache hit, contents of both caches remain unchanged. If access $h + 1$ is a cache miss, B replaces the least-recently used cache line. Recall that we make assumptions to ensure that cache $i + 1$ can include all contents of cache i . According to the inductive assumption, since cache i holds the cache blocks most recently accessed by the processor, B cannot replace a cache line that is marked in A . Therefore, B replaces the least-recently used cache line that is not marked in A . The unmarked cache lines in A are held in the order in which cache lines from B are thrown out. Again, from the inductive assumption, B rejects cache lines in the LRU order of accesses made by the processor. Thus, A also replaces the least-recently used line that is not marked, which completes the induction. \square

LEMMA 6.4. *An optimal cache-oblivious algorithm whose cache complexity satisfies the regularity condition (14) incurs an optimal number of cache misses on each level³ of a multilevel cache with LRU replacement.*

PROOF. Let cache i in the multilevel LRU model be a $(\mathcal{M}_i, \mathcal{B}_i)$ cache. Lemma 6.3 says that the cache holds exactly the same elements as a $(\mathcal{M}_i, \mathcal{B}_i)$ cache in a two-level LRU model. From Corollary 6.2, the cache complexity of a cache-oblivious algorithm working on a $(\mathcal{M}_i, \mathcal{B}_i)$ LRU cache lower-bounds that of any cache-aware algorithm for a $(\mathcal{M}_i, \mathcal{B}_i)$ ideal cache. A $(\mathcal{M}_i, \mathcal{B}_i)$ level in a multilevel cache incurs at least as many cache misses as a $(\mathcal{M}_i, \mathcal{B}_i)$ ideal cache when the same algorithm is executed. \square

Finally, we remove the two assumptions of automatic replacement and full associativity. Specifically, we shall show that a fully associative LRU cache can be maintained in ordinary memory with no asymptotic loss in expected performance.

LEMMA 6.5. *A $(\mathcal{M}, \mathcal{B})$ LRU-cache can be maintained using $O(\mathcal{M})$ memory locations such that every access to a cache block in memory takes $O(1)$ expected time.*

³Alpern et al. [1990] show that optimality on each level of memory in the UMH model does not necessarily imply global optimality. The UMH model incorporates a single cost measure that combines the costs of work and cache faults at each of the levels of memory. By analyzing the levels independently, our multilevel ideal-cache model remains agnostic about the various schemes by which work and cache faults might be combined.

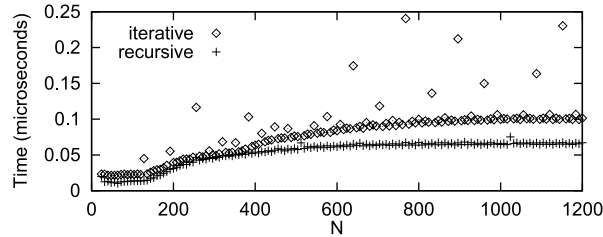

Fig. 4. Average time to transpose an $N \times N$ matrix, divided by N^2 .

PROOF. Given the address of the memory location to be accessed, we use a 2-universal hash function [Motwani and Raghavan 1995, p. 216] to maintain a hash table of cache blocks present in the memory. The M/B entries in the hash table point to linked lists in a heap of memory that contains M/B records corresponding to the cache lines. The 2-universal hash function guarantees that the expected size of a chain is $O(1)$. All records in the heap are organized as a doubly linked list in the LRU order. Thus, the LRU policy can be implemented in $O(1)$ expected time using $O(M/B)$ records of $O(B)$ words each. \square

THEOREM 6.6. *An optimal cache-oblivious algorithm whose cache-complexity bound satisfies the regularity condition (14) can be implemented optimally in expectation in multilevel models with explicit memory management.*

PROOF. Combine Lemma 6.4 and Lemma 6.5. \square

COROLLARY 6.7. *The recursive cache-oblivious algorithms for matrix multiplication, matrix transpose, FFT, and sorting are optimal in multilevel models with explicit memory management.*

PROOF. Their complexity bounds satisfy the regularity condition (14). \square

It can also be shown [Prokop 1999] that cache-oblivious algorithms satisfying (14) are also optimal (in expectation) in the previously studied SUMH [Alpern et al. 1990; Vitter and Nodine 1993] and HMM [Aggarwal et al. 1987a] models. Thus, all the algorithmic results in this article apply to these models, matching the best bounds previously achieved.

Other simulation results can be shown. For example, by using the copying technique of Lam et al. [1991], cache-oblivious algorithms for matrix multiplication and other problems can be designed that are provably optimal on direct-mapped caches.

7. EMPIRICAL RESULTS

The theoretical work presented in this article was motivated by the practical concerns of programming computers with hierarchical memory systems. This section presents empirical results for matrix transpose and matrix multiplication showing that cache-oblivious algorithms can indeed obtain high performance in practice.

Figure 4 compares per-element time to transpose a matrix using the naive iterative algorithm employing a doubly nested loop with the recursive cache-oblivious REC-TRANSPPOSE algorithm from Section 3. The two algorithms were evaluated on a 450 megahertz AMD K6III processor with a 32-kilobyte 2-way set-associative L1 cache, a 64-kilobyte 4-way set-associative L2 cache, and a 1-megabyte L3 cache of unknown associativity, all with 32-byte cache lines. The code for REC-TRANSPPOSE was the same as presented in Section 3, except that the divide-and-conquer structure was modified to produce exact powers of 2 as submatrix sizes wherever possible. In addition, the

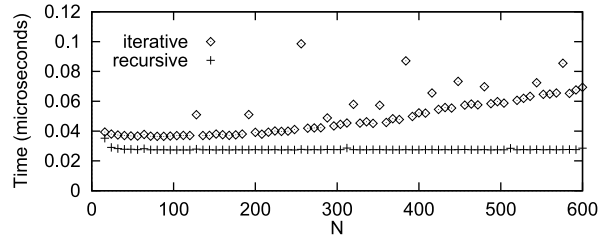

Fig. 5. Average time taken to multiply two $N \times N$ matrices, divided by N^3 .

base cases were “coarsened” by inlining the recursion near the leaves to increase their size and overcome the overhead of procedure calls. (A good research problem is to determine an effective compiler strategy for coarsening base cases automatically.)

Although these results must be considered preliminary, Figure 4 strongly indicates that the recursive algorithm outperforms the iterative algorithm throughout the range of matrix sizes. Moreover, the iterative algorithm behaves erratically, apparently due to so-called “conflict” misses [Hennessy and Patterson 1996, p. 390], where limited cache associativity interacts with the regular addressing of the matrix to cause systematic interference. Blocking the iterative algorithm should help with conflict misses [Lam et al. 1991], but it would make the algorithm cache aware. For large matrices, the recursive algorithm executes in less than 70% of the time used by the iterative algorithm, even though the transpose problem exhibits no temporal locality.

Figure 5 makes a similar comparison between the naive iterative matrix-multiplication algorithm, which uses three nested loops, with the $O(n^3)$ -work recursive REC-MULT algorithm described in Section 2. This problem exhibits a high degree of temporal locality, which REC-MULT exploits effectively. As the figure shows, the average time used per integer multiplication in the recursive algorithm is almost constant, which for large matrices, is less than 50% of the time used by the iterative variant. A similar study for Jacobi multipass filters can be found in Prokop [1999].

8. RELATED WORK

In this section, we discuss the origin of the notion of cache-obliviousness. We also give an overview of other hierarchical memory models.

Our research group at MIT noticed as far back as 1994 that divide-and-conquer matrix multiplication was a cache-optimal algorithm that required no tuning, but we did not adopt the term “cache-oblivious” until 1997. This matrix-multiplication algorithm, as well as a cache-oblivious algorithm for LU-decomposition without pivoting, eventually appeared in Blumofe et al. [1996]. Shortly after leaving our research group, Toledo [1997] independently proposed a cache-oblivious algorithm for LU-decomposition with pivoting. For $n \times n$ matrices, Toledo’s algorithm uses $\Theta(n^3)$ work and incurs $\Theta(1 + n^2/\mathcal{B} + n^3/\mathcal{B}\sqrt{\mathcal{M}})$ cache misses. Our group has produced an FFT library called FFTW [Frigo 1999; Frigo and Johnson 1998], which employs a register-allocation and scheduling algorithm inspired by our cache-oblivious FFT algorithm. The general idea that divide-and-conquer enhances memory locality has been known for a long time [Singleton 1969]. Other researchers [Chatterjee et al. 1999b; Frens and Wise 1997] have also observed that recursive algorithms exhibit performance advantages over iterative algorithms for computers with caches.

Previous theoretical work on understanding hierarchical memories and the I/O-complexity of algorithms has been studied in cache-aware models lacking an automatic replacement strategy, although Carter and Gatlin [1998] and Sen et al. [2002] are exceptions. Hong and Kung [1981] use the red-blue pebble game to prove lower bounds

on the I/O-complexity of matrix multiplication, FFT, and other problems. The red-blue pebble game models temporal locality using two levels of memory. The model was extended by Savage [1995] for deeper memory hierarchies. Aggarwal and Vitter [1988] introduced spatial locality and investigated a two-level memory in which a block of P contiguous items can be transferred in one step. They obtained tight bounds for matrix multiplication, FFT, sorting, and other problems. The hierarchical memory model (HMM) by Aggarwal et al. [1987a] treats memory as a linear array, where the cost of an access to element at location x is given by a cost function $f(x)$. The BT model [Aggarwal et al. 1987b] extends HMM to support block transfers. The UMH model by Alpern et al. [1990] is a multilevel model that allows I/O at different levels to proceed in parallel. Vitter and Shriver introduce parallelism, and they give algorithms for matrix multiplication, FFT, sorting, and other problems in both a two-level model [Vitter and Shriver 1994a] and several parallel hierarchical memory models [Vitter and Shriver 1994b]. Vitter [1999] provides a comprehensive survey of external-memory algorithms.

Since 1999, when the conference version [Frigo et al. 1999] of this article was published, nearly 1500 papers have appeared that reference the term “cache-oblivious,” according to Google Scholar. Seminal among them is the paper by Bender et al. [2000] on cache-oblivious B-trees, which sparked a flurry of research into data structures that use hierarchical memory near optimally despite having no dependence on hardware parameters. Excellent surveys on cache-oblivious algorithms and data structures include [Arge et al. 2005; Brodal 2004; Demaine 2002].

ACKNOWLEDGMENTS

Thanks to Bobby Blumofe, now of Akamai Technologies, who sparked early discussions at MIT about what we now call cache obliviousness. Thanks to Gianfranco Bilardi of University of Padova, Sid Chatterjee now of IBM Research, Chris Joerg now of Akamai Technologies, Martin Rinard of MIT, Bin Song Cheyney now of Google Corporation, Sivan Toledo of Tel-Aviv University, and David Wise of Indiana University for helpful discussions. The conference version [Frigo et al. 1999] of this article showed an incorrect formula for the cache complexity of Strassen’s algorithm. We are indebted to Jim Demmel of UC Berkeley for reporting the error to us.

REFERENCES

- AGGARWAL, A. AND VITTER, J. S. 1988. The input/output complexity of sorting and related problems. *Comm. ACM* 31, 9, 1116–1127.
- AGGARWAL, A., ALPERN, B., CHANDRA, A. K., AND SNIR, M. 1987a. A model for hierarchical memory. In *Proceedings of the 19th Annual ACM Symposium on Theory of Computing (STOC)*. 305–314.
- AGGARWAL, A., CHANDRA, A. K., AND SNIR, M. 1987b. Hierarchical memory with block transfer. In *Proceedings of the 28th Annual Symposium on Foundations of Computer Science (FOCS)*. IEEE, Los Alamitos, CA, 204–216.
- AHO, A. V., HOPCROFT, J. E., AND ULLMAN, J. D. 1974. *The Design and Analysis of Computer Algorithms*. Addison-Wesley Publishing Company.
- ALPERN, B., CARTER, L., AND FEIG, E. 1990. Uniform memory hierarchies. In *Proceedings of the 31st Annual IEEE Symposium on Foundations of Computer Science (FOCS)*. 600–608.
- ARGE, L., BRODAL, G. S., AND FAGERBERG, R. 2005. Cache-oblivious data structures. In *Handbook of Data Structures and Applications*, D. Mehta and S. Sahni Eds., CRC Press, Chapter 34, 27.
- BAILEY, D. H. 1990. FFTs in external or hierarchical memory. *J. Supercomput.* 4, 1, 23–35.
- BELADY, L. A. 1966. A study of replacement algorithms for virtual storage computers. *IBM Syst. J.* 5, 2, 78–101.
- BENDER, M. A., DEMAINE, E., AND FARACH-COLTON, M. 2000. Cache-oblivious B-trees. In *Proceedings of the 41st Annual Symposium on Foundations of Computer Science (FOCS)*. 399–409.

- BILARDI, G. AND PESERICO, E. 2001. A characterization of temporal locality and its portability across memory hierarchies. In *Automata, Languages and Programming*, Orejas, F., Spirakis, P., van Leeuwen, J. Eds., Lecture Notes in Computer Science, vol. 2076, Springer, Berlin, 128–139.
- BLUMOFÉ, R. D., FRIGO, M., JOERG, C. F., LEISERSON, C. E., AND RANDALL, K. H. 1996. An analysis of dag-consistent distributed shared-memory algorithms. In *Proceedings of the 8th Annual ACM Symposium on Parallel Algorithms and Architectures (SPAA)*. 297–308.
- BRODAL, G. 2004. Cache-oblivious algorithms and data structures. In *Algorithm Theory - SWAT 2004*, T. Hagerup and J. Katajainen Eds., Lecture Notes in Computer Science Series, vol. 3111. Springer Berlin/Heidelberg, 3–13.
- CARTER, L. AND GATLIN, K. S. 1998. Towards an optimal bit-reversal permutation program. In *Proceedings of the 39th Annual Symposium on Foundations of Computer Science*. IEEE Computer Society Press, 544–555.
- CHATTERJEE, S., JAIN, V. V., LEBECK, A. R., AND MUNDHRA, S. 1999a. Nonlinear array layouts for hierarchical memory systems. In *Proceedings of the ACM International Conference on Supercomputing*.
- CHATTERJEE, S., LEBECK, A. R., PATNALA, P. K., AND THOTTETHODI, M. 1999b. Recursive array layouts and fast parallel matrix multiplication. In *Proceedings of the 11th ACM Symposium on Parallel Algorithms and Architectures (SPAA)*.
- COOLEY, J. W. AND TUKEY, J. W. 1965. An algorithm for the machine computation of the complex Fourier Series. *Math. Comput.* 19, 297–301.
- CORMEN, T. H., LEISERSON, C. E., AND RIVEST, R. L. 1990. *Introduction to Algorithms*. MIT Press and McGraw Hill.
- DEMAINE, E. D. 2002. Cache-oblivious algorithms and data structures. In *Lecture Notes from the EEF Summer School on Massive Data Sets*. BRICS, University of Aarhus, Denmark.
- DUHAMEL, P. AND VETTERLI, M. 1990. Fast Fourier transforms: a tutorial review and a state of the art. *Sig. Proc.* 19, 259–299.
- FRENS, J. D. AND WISE, D. S. 1997. Auto-blocking matrix-multiplication or tracking BLAS3 performance from source code. In *Proceedings of the 6th ACM SIGPLAN Symposium on Principles and Practice of Parallel Programming (PPoPP)*. 206–216.
- FRIGO, M. 1999. A fast Fourier transform compiler. In *Proceedings of the ACM SIGPLAN'99 Conference on Programming Language Design and Implementation (PLDI)*.
- FRIGO, M. AND JOHNSON, S. G. 1998. FFTW: An adaptive software architecture for the FFT. In *Proceedings of the International Conference on Acoustics, Speech, and Signal Processing*.
- FRIGO, M., LEISERSON, C. E., PROKOP, H., AND RAMACHANDRAN, S. 1999. Cache-oblivious algorithms. In *Proceedings of the 40th Annual Symposium on Foundations of Computer Science*. 285–297.
- GOLUB, G. H. AND VAN LOAN, C. F. 1989. *Matrix Computations*. Johns Hopkins University Press.
- HENNESSY, J. L. AND PATTERSON, D. A. 1996. *Computer Architecture: A Quantitative Approach* 2nd Ed. Morgan-Kaufmann.
- HONG, J.-W. AND KUNG, H. T. 1981. I/O complexity: The red-blue pebbling game. In *Proceedings of the 13th Annual ACM Symposium on Theory of Computing (STOC)*. 326–333.
- LAM, M. S., ROTHBERG, E., AND WOLF, M. E. 1991. The cache performance and optimizations of blocked algorithms. In *Proceedings of the 4th International Conference on Architectural Support for Programming Languages and Operating Systems (ASPLOS)*. ACM SIGPLAN Notices 26, 4, 63–74.
- LAMARCA, A. AND LADNER, R. E. 1997. The influence of caches on the performance of sorting. In *Proceedings of the 8th Annual ACM-SIAM Symposium on Discrete Algorithms (SODA)*. 370–377.
- MOTWANI, R. AND RAGHAVAN, P. 1995. *Randomized Algorithms*. Cambridge University Press.
- NODINE, M. H. AND VITTER, J. S. 1993. Deterministic distribution sort in shared and distributed memory multiprocessors. In *Proceedings of the 5th ACM Symposium on Parallel Algorithms and Architectures (SPAA)*. 120–129.
- PROKOP, H. 1999. Cache-oblivious algorithms. M.S. thesis, Massachusetts Institute of Technology.
- SAVAGE, J. E. 1995. Extending the Hong-Kung model to memory hierarchies. In *Computing and Combinatorics*. D.-Z. Du and M. Li Eds., Lecture Notes in Computer Science Series, vol. 959, Springer-Verlag, 270–281.
- SEN, S., CHATTERJEE, S., AND DUMIR, N. 2002. Towards a theory of cache-efficient algorithms. *J. ACM* 49, 6, 828–858.
- SINGLETON, R. C. 1969. An algorithm for computing the mixed radix fast Fourier transform. *IEEE Trans. Audio Electro. AU-17*, 2, 93–103.

- SLEATOR, D. D. AND TARJAN, R. E. 1985. Amortized efficiency of list update and paging rules. *Comm. ACM* 28, 2, 202–208.
- STRASSEN, V. 1969. Gaussian elimination is not optimal. *Numer. Math.* 13, 354–356.
- TOLEDO, S. 1997. Locality of reference in LU decomposition with partial pivoting. *SIAM J. Matrix Analysis and Applications* 18, 4, 1065–1081.
- VITTER, J. S. 1999. External memory algorithms and data structures. In *External Memory Algorithms and Visualization*, J. Abello and J. S. Vitter Eds., DIMACS Series in Discrete Mathematics and Theoretical Computer Science, American Mathematical Society Press. Providence, RI.
- VITTER, J. S. AND NODINE, M. H. 1993. Large-scale sorting in uniform memory hierarchies. *J. Parallel Distrib. Comput.* 17, 1–2, 107–114.
- VITTER, J. S. AND SHRIVER, E. A. M. 1994a. Algorithms for parallel memory I: Two-level memories. *Algorithmica* 12, 2/3, 110–147.
- VITTER, J. S. AND SHRIVER, E. A. M. 1994b. Algorithms for parallel memory II: Hierarchical multilevel memories. *Algorithmica* 12, 2/3, 148–169.
- WINOGRAD, S. 1970. On the algebraic complexity of functions. *Actes du Congrès International des Mathématiciens* 3, 283–288.

Received November 2011; accepted November 2011