

PERMUTATIONS DEFINING CONVEX PERMUTOMINOES

A. BERNINI, F. DISANTO, R. PINZANI, AND S. RINALDI

ABSTRACT. A permutomino of size n is a polyomino determined by particular pairs (π_1, π_2) of permutations of size n , such that $\pi_1(i) \neq \pi_2(i)$, for $1 \leq i \leq n$. Here we determine the combinatorial properties and, in particular, the characterization for the pairs of permutations defining convex permutominoes.

Using such a characterization, these permutations can be uniquely represented in terms of the so called square permutations, introduced by Mansour and Severini. Then, we provide a closed formula for the number of these permutations with size n .

1. CONVEX POLYOMINOES

In the plane $\mathbb{Z} \times \mathbb{Z}$ a *cell* is a unit square, and a *polyomino* is a finite connected union of cells having no cut point. Polyominoes are defined up to translations (see Figure 1 (a)). A *column* (*row*) of a polyomino is the intersection between the polyomino and an infinite strip of cells lying on a vertical (horizontal) line.

Polyominoes were introduced by Golomb [17], and then they have been studied in several mathematical problems, such as tilings [2, 16], or games [15] among many others. The enumeration problem for general polyominoes is difficult to solve and still open. The number a_n of polyominoes with n cells is known up to $n = 56$ [18] and asymptotically, these numbers satisfy the relation $\lim_n (a_n)^{1/n} = \mu$, $3.96 < \mu < 4.64$, where the lower bound is a recent improvement [1].

In order to simplify enumeration problems of polyominoes, several subclasses were defined by combining the two simple notions of *convexity* and *directed growth*. A polyomino is said to be *column convex* (resp. *row convex*) if every its column (resp. row) is connected (see Figure 1 (b)). A polyomino is said to be *convex*, if it is both row and column convex (see Figure 1 (c)). The *area* of a polyomino is just the number of cells it contains, while its *semi-perimeter* is half the number of edges of cells in its boundary. Thus, for any convex polyomino the semi-perimeter is the sum of the numbers of its rows and columns. Moreover, any convex polyomino is contained in a rectangle in the square lattice which has the same semi-perimeter, called *minimal bounding rectangle*.

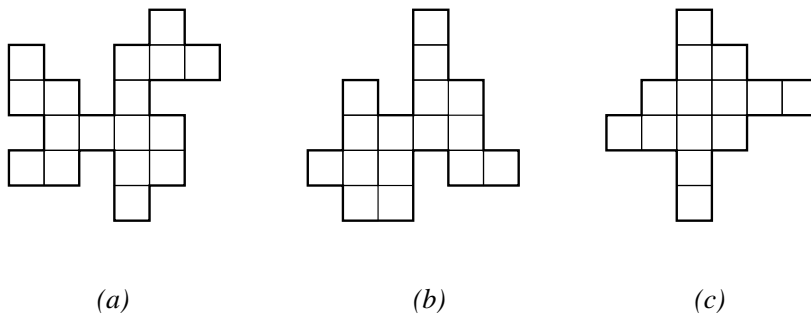

FIGURE 1. (a) a polyomino; (b) a column convex polyomino which is not row convex; (c) a convex polyomino.

Delest and Viennot [11] obtained a first significant result in the enumeration of convex polyominoes. They proved that the number ℓ_n of convex polyominoes with semi-perimeter equal to $n + 2$ is

$$(1) \quad \ell_{n+2} = (2n + 1)4^n - 4(2n + 1) \binom{2n}{n}, \quad n \geq 2; \quad \ell_0 = 1, \quad \ell_1 = 2.$$

whose first terms (sequence A005436 [21]) are

$$1, 2, 7, 28, 120, 528, 2344, 10416, \dots$$

During the last two decades convex polyominoes, and several combinatorial objects obtained as a generalizations of this class, have been studied by various points of view. For the main results concerning the enumeration and other combinatorial properties of convex polyominoes we refer to [4, 5, 6, 8].

There are two other classes of convex polyominoes which will be useful in the paper, the *directed convex polyominoes* and the *parallelogram polyominoes*. A polyomino is said to be *directed* when each of its cells can be reached from a distinguished cell, called *root*, by a path which is contained in the polyomino and uses only north and east unitary steps.

A polyomino is *directed convex* if it is both directed and convex (see Figure 2 (a)). It is known that the number of directed convex polyominoes of semi-perimeter $n + 2$ is equal to the n th central binomial coefficient (sequence A000984 [21]), i.e.,

$$(2) \quad b_n = \binom{2n}{n}.$$

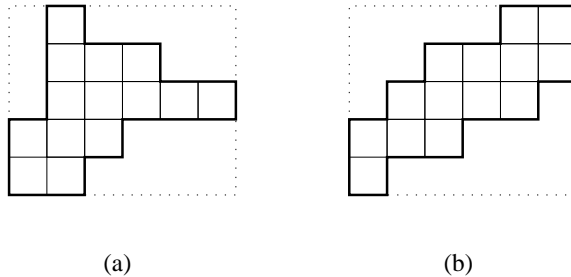

FIGURE 2. (a) A directed convex polyomino; (b) a parallelogram polyomino.

Finally, *parallelogram polyominoes* are a special subset of the directed convex ones, defined by two lattice paths that use north and east unit steps, and intersect only at their origin and extremity. These paths are called the *upper* and the *lower path* (see Figure 2 (b)). It is known [22] that the number of parallelogram polyominoes having semi-perimeter $n + 1$ is the n -th *Catalan number* (sequence A000108 [21]),

$$(3) \quad c_n = \frac{1}{n+1} \binom{2n}{n}.$$

2. CONVEX PERMUTOMINOES

Let P be a polyomino without holes, having n rows and columns, $n \geq 1$; we assume without loss of generality that the south-west corner of its minimal bounding rectangle is placed in $(1, 1)$. Let $\mathcal{A} = (A_1, \dots, A_{2(r+1)})$ be the list of its vertices (i.e., corners of its boundary) ordered in a clockwise sense starting from the lowest leftmost vertex. We say that P is a *permutomino* if $\mathcal{P}_1 = (A_1, A_3, \dots, A_{2r+1})$ and $\mathcal{P}_2 = (A_2, A_4, \dots, A_{2r+2})$ represent two permutations of \mathcal{S}_{n+1} , where, as usual, \mathcal{S}_n

is the symmetric group of size n . Obviously, if P is a permutomino, then $r = n$, and $n + 1$ is called the *size* of the permutomino. The two permutations defined by \mathcal{P}_1 and \mathcal{P}_2 are indicated by $\pi_1(P)$ and $\pi_2(P)$, respectively (see Figure 3).

From the definition any permutomino P has the property that, for each abscissa (ordinate) there is exactly one vertical (horizontal) side in the boundary of P with that coordinate. It is simple to observe that this property is also a sufficient condition for a polyomino to be a permutomino. By convention we also consider the empty permutomino of size 1, associated with $\pi = (1)$.

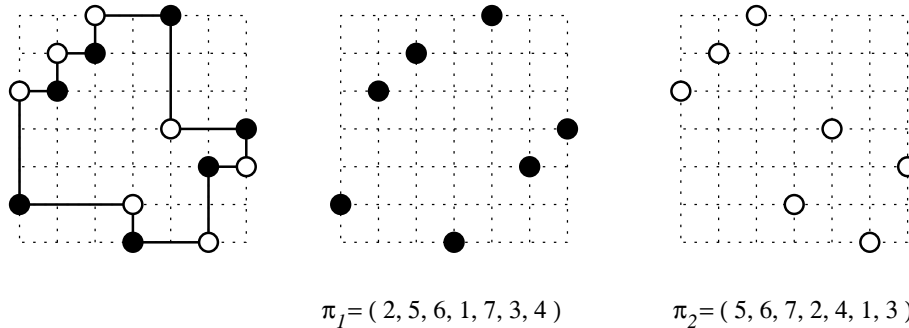

FIGURE 3. A permutomino and the two associated permutations.

Permutominoes were introduced by F. Incitti [19] while studying the problem of determining the \tilde{R} -polynomials (related with the Kazhdan-Lusztig R-polynomials) associated with a pair (π_1, π_2) of permutations. Concerning the class of polyominoes without holes, our definition (though different) turns out to be equivalent to Incitti's one, which is more general but uses some algebraic notions not necessary in this paper.

Let us recall the main enumerative results concerning convex permutominoes. Using bijective techniques, it is possible to prove [14] that the number of *parallelogram permutominoes* of size $n + 1$ is equal to c_n and that the number of *directed-convex permutominoes* of size $n + 1$ is equal to $\frac{1}{2} b_n$, where, throughout all the paper, c_n and b_n will denote, respectively, the Catalan numbers and the central binomial coefficients. Finally, Disanto et al. [13] proved, by the ECO method, that the number of *convex permutominoes* of size $n + 1$ is

$$(4) \quad 2(n + 3)4^{n-2} - \frac{n}{2} \binom{2n}{n} \quad n \geq 1.$$

The first terms of the above sequence (A126020 [21]) are

$$1, 1, 4, 18, 84, 394, 1836, 8468, \dots$$

The same formula has been obtained independently by Boldi et al. [3]. The main results concerning the enumeration of classes of convex permutominoes [13, 14] are listed in Table 2, where the first terms of the sequences are given starting from $n = 1$.

Notation. Throughout the whole paper we are going to use the following notations:

- \mathcal{C}_n is the set of convex permutominoes of size n ;
- C_n is the cardinality of \mathcal{C}_n ;
- $C(x)$ is the generating function of the sequence $\{C_n\}_{n \geq 2}$.

Moreover, if π is a permutation of size n , then we define its *reversal* π^R and its *complement* π^C as follows: $\pi^R(i) = \pi(n + 1 - i)$ and $\pi^C(i) = n + 1 - \pi(i)$, for each $i = 1, \dots, n$.

<i>Class</i>	<i>First terms</i>	<i>Closed form/rec. relation</i>
convex	1, 1, 4, 18, 84, 394, ...	$C_{n+1} = 2(n+3)4^{n-2} - \frac{n}{2} \binom{2n}{n}$
directed convex	1, 1, 3, 10, 35, 126, ...	$D_{n+1} = \frac{1}{2} b_n$
parallelogram	1, 1, 2, 5, 14, 42, 132, ...	$P_{n+1} = c_n$
symmetric (w.r.t. $x = y$)	1, 1, 2, 4, 10, 22, 54, ...	$Sym_{n+1} = (n+3)2^{n-2} - n \binom{n-1}{\lfloor \frac{n-1}{2} \rfloor} - (n-1) \binom{n-2}{\lfloor \frac{n-2}{2} \rfloor}$
centered	1, 1, 4, 16, 64, 256, ...	$Q_n = 4^{n-2}$
bi-centered	1, 1, 4, 14, 48, 164, ...	$T_n = 4T_{n-1} - 2T_{n-2}, \quad n \geq 3$
stacks	1, 1, 2, 4, 8, 16, 32, ...	$St_n = 2^{n-2}$

3. PERMUTATIONS ASSOCIATED WITH CONVEX PERMUTOMINOES

Given a permutomino P , the two permutations associated with P are denoted by π_1 and π_2 (see Figure 3). While it is clear that any permutomino of size $n \geq 2$ uniquely determines two permutations π_1 and π_2 of \mathcal{S}_n , with

- 1: $\pi_1(i) \neq \pi_2(i), 1 \leq i \leq n,$
- 2: $\pi_1(1) < \pi_2(1),$ and $\pi_1(n) > \pi_2(n),$

there are pairs of permutations (π_1, π_2) of n satisfying 1 and 2 and not defining a permutomino: Figure 4 depicts the two problems which may occur.

Frosini et al. [14] give a simple constructive proof that every permutation of \mathcal{S}_n is associated with at least one column convex permutomino.

Proposition 1. *If $\pi \in \mathcal{S}_n$ then there is at least one column convex permutomino P such that $\pi = \pi_1(P)$ or $\pi = \pi_2(P)$.*

For instance, Figure 5 (a) depicts a column convex permutomino associated with the permutation π_1 in Figure 4 (b).

The statement of Proposition 1 does not hold for convex permutominoes. Therefore, in this paper we consider the class \mathcal{C}_n of convex permutominoes of size n , and study the problem of giving a characterization for the set of permutations defining convex permutominoes,

$$\{ (\pi_1(P), \pi_2(P)) : P \in \mathcal{C}_n \}.$$

Moreover, let us consider the following subsets of \mathcal{S}_n :

$$\tilde{\mathcal{C}}_n = \{ \pi_1(P) : P \in \mathcal{C}_n \}, \quad \tilde{\mathcal{C}}'_n = \{ \pi_2(P) : P \in \mathcal{C}_n \}.$$

It is easy to prove the following properties:

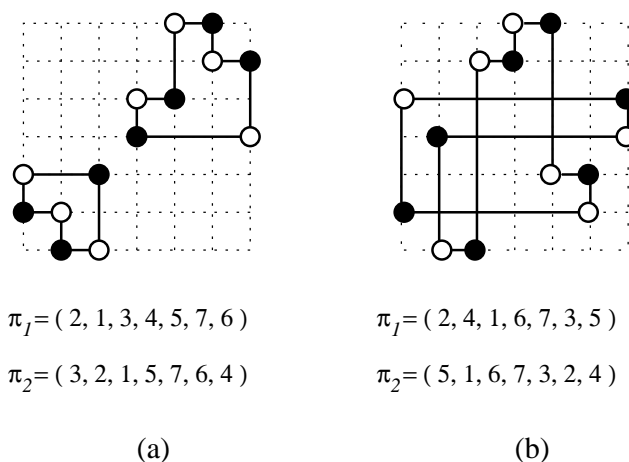

FIGURE 4. Two permutations π_1 and π_2 of \mathcal{S}_n , satisfying 1 and 2, do not necessarily define a permutomino, since two problems may occur: (a) two disconnected sets of cells; (b) the boundary crosses itself.

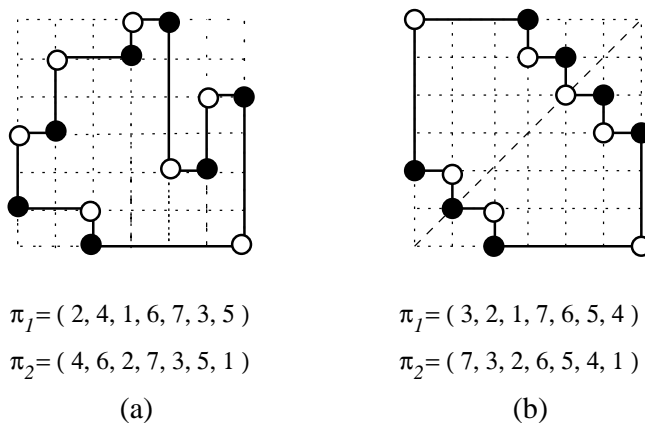

FIGURE 5. (a) a column convex permutomino associated with the permutation π_1 in Figure 4 (b); (b) the symmetric permutomino associated with the involution $\pi_1 = (3, 2, 1, 7, 6, 5, 4)$.

- (1) $|\tilde{\mathcal{C}}_n| = |\tilde{\mathcal{C}}'_n|$,
- (2) $\pi \in \tilde{\mathcal{C}}_n$ if and only if $\pi^R \in \tilde{\mathcal{C}}'_n$.
- (3) If P is symmetric according to the diagonal $x = y$, then $\pi_1(P)$ and $\pi_2(P)$ are both *involutions* of \mathcal{S}_n . We recall that an involution is a permutation where all the cycles have length at most 2 (see for instance Figure 5 (b)). Figures 6 and 16 show permutominoes where only π_1 is an involution, and this condition is not sufficient for the permutomino to be symmetric.

Given a permutation $\pi \in \mathcal{S}_n$, we say that π is π_1 -associated (briefly *associated*) with a permutomino P , if $\pi = \pi_1(P)$. With no loss of generality, we will study the combinatorial properties of the permutations of $\tilde{\mathcal{C}}_n$, and we will give a simple way to recognize if a permutation π is in $\tilde{\mathcal{C}}_n$ or not. Moreover, we will study the cardinality of this set. In particular, we will exploit the relations between the cardinalities of \mathcal{C}_n and of $\tilde{\mathcal{C}}_n$.

For small values of n we have that:

$$\begin{aligned}\tilde{\mathcal{C}}_1 &= \{1\}, \\ \tilde{\mathcal{C}}_2 &= \{12\}, \\ \tilde{\mathcal{C}}_3 &= \{123, 132, 213\}, \\ \tilde{\mathcal{C}}_4 &= \{1234, 1243, 1324, 1342, 1423, 1432, 2143, \\ &\quad 2314, 2134, 2413, 3124, 3142, 3214\}.\end{aligned}$$

As a main result we will prove that the cardinality of $\tilde{\mathcal{C}}_{n+1}$ is

$$(5) \quad 2(n+2)4^{n-2} - \frac{n}{4} \binom{3-4n}{1-2n} \binom{2n}{n}, \quad n \geq 1,$$

(sequence A122122 [21]) the first terms being

$$1, 1, 3, 13, 62, 301, 1450, \dots$$

For any $\pi \in \tilde{\mathcal{C}}_n$, let us consider also

$$[\pi] = \{P \in \mathcal{C}_n : \pi_1(P) = \pi\},$$

i.e., the set of convex permutominoes associated with π . For instance, there are 4 convex permutominoes associated with $\pi = (2, 1, 3, 4, 5)$, as depicted in Figure 6. In this paper we will also give a simple way of computing $[\pi]$, for any given $\pi \in \tilde{\mathcal{C}}_n$.

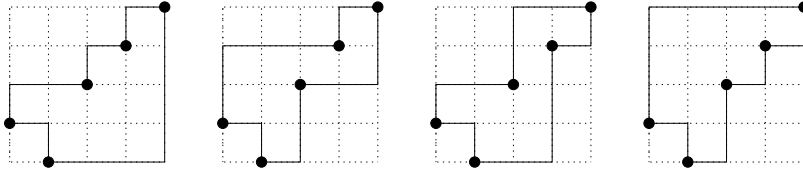

FIGURE 6. The four convex permutominoes associated with $(2, 1, 3, 4, 5)$.

3.1. A matrix representation of convex permutominoes. Before going on with the study of convex permutominoes, we would like to point out a simple property of their boundary, related to *reentrant* and *salient points*. Let us briefly recall the definition of these objects.

Let P be a polyomino; starting from the leftmost point having minimal ordinate, and moving in a clockwise sense, the boundary of P can be encoded as a word in a four letter alphabet, $\{N, E, S, W\}$, where N (resp., E, S, W) represents a *north* (resp., *east, south, west*) unit step. Any occurrence of a sequence NE, ES, SW , or WN in the word encoding P defines a *salient point* of P , while any occurrence of a sequence EN, SE, WS , or NW defines a *reentrant point* of P (see for instance, Figure 7).

It is possible to prove [10, 7] that, in a more generale context, the difference between the number of salient and reentrant points of any polyomino is equal to 4.

In a convex permutomino of size $n + 1$ the length of the word coding the boundary is $4n$, and we have $n+3$ salient points and $n-1$ reentrant points; moreover, we observe that a reentrant point cannot lie on the minimal bounding rectangle. This leads to the following remarkable property:

Proposition 2. *The set of reentrant points of a convex permutomino of size $n + 1$ defines a permutation matrix of dimension $n - 1$, $n \geq 1$.*

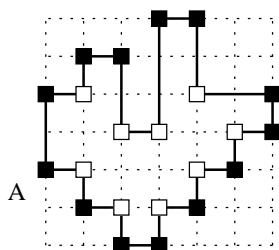

NNENESSENNNESSEESWSWSWSWNWNW

FIGURE 7. The coding of the boundary of a polyomino, starting from A and moving in a clockwise sense; its salient (resp. reentrant) points are indicated by black (resp. white) squares.

For simplicity of notation, we agree to group the reentrant points of a convex permutomino in four classes; in practice we choose to represent the reentrant point determined by a sequence EN (resp. SE , WS , NW) with the symbol α (resp. β , γ , δ).

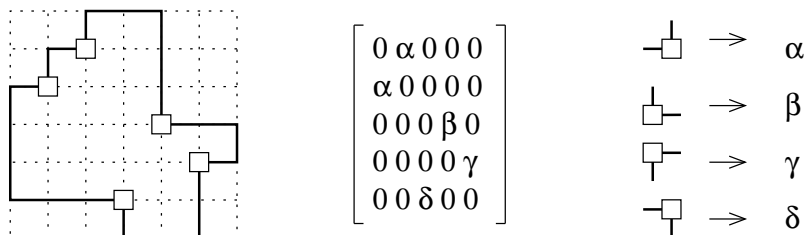

FIGURE 8. The reentrant points of a convex permutomino uniquely define a permutation matrix in the symbols α , β , γ and δ .

Using this notation we can state the following simple characterization for convex permutominoes:

Proposition 3. *A convex permutomino of size $n \geq 2$ is uniquely represented by the permutation matrix defined by its reentrant points, which has dimension $n - 2$, and uses the symbols α , β , γ , δ , and such that for all points A, B, C, D , of type α , β , γ and δ , respectively, we have:*

- (1) $x_A < x_B$, $x_D < x_C$, $y_A > y_D$, $y_B > y_C$;
- (2) $\neg(x_A > x_C \wedge y_A < y_C)$ and $\neg(x_B < x_D \wedge y_B < y_D)$,
- (3) *the ordinates of the α and of γ points are strictly increasing, from left to right; the ordinates of the β and of δ points are strictly decreasing, from left to right.*

where x and y denote the abscissa and the ordinate of the considered point.

Just to give a more informal explanation, on a convex permutomino, let us consider the special points

$$A = (1, \pi_1(1)), \quad B = (\pi_1^{-1}(n), n), \quad C = (n, \pi_1(n)), \quad D = (\pi_1^{-1}(1), 1).$$

The path that goes from A to B (resp. from B to C , from C to D , and from D to A) in a clockwise sense is made only of α (resp. β , γ , δ) points, thus it is called the α -path (resp. β -path, γ -path, δ -path) of the permutomino. The situation is schematically sketched in Figure 9.

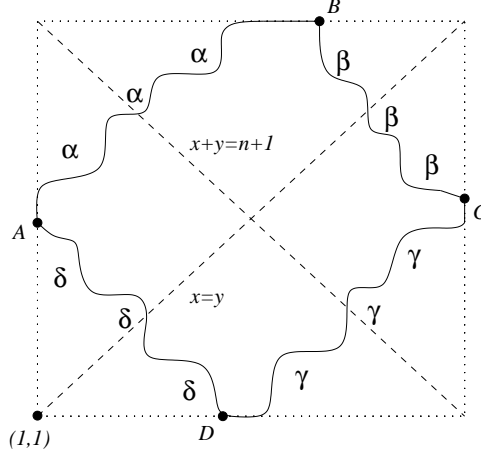

FIGURE 9. A sketched representation of the α , β , γ and δ paths in a convex permutomino.

From the characterization given in Proposition 3 we have the following two properties:

- (z1): the α points are never below the diagonal $x = y$, and the γ points are never above the diagonal $x = y$.
- (z2): the β points are never below the diagonal $x + y = n + 1$, and the δ points are never above the diagonal $x + y = n + 1$.

3.2. Characterization and combinatorial properties of $\tilde{\mathcal{C}}_n$. Let us consider the problem of establishing, for a given permutation $\pi \in \mathcal{S}_n$, if there is at least a convex permutomino P of size n such that $\pi_1(P) = \pi$.

Let π be a permutation of \mathcal{S}_n , we define $\mu(\pi)$ (briefly μ) as the maximal upper unimodal sublist of π (μ retains the indexing of π).

Specifically, if μ is denoted by $(\mu(i_1), \dots, n, \dots, \mu(i_m))$, then we have the following:

- (1) $\mu(i_1) = \mu(1) = \pi(1)$;
- (2) if $n \notin \{\mu(i_1), \dots, \mu(i_k)\}$, then $\mu(i_{k+1}) = \pi(i_{k+1})$ such that
 - i: $i_k < i < i_{k+1}$ implies $\pi(i) < \mu(i_k)$, and
 - ii: $\pi(i_{k+1}) > \mu(i_k)$;
- (3) if $n \in \{\mu(i_1), \dots, \mu(i_k)\}$, then $\mu(i_{k+1}) = \pi(i_{k+1})$ such that
 - i: $i_k < i < i_{k+1}$ implies $\pi(i) < \pi(i_{k+1})$, and
 - ii: $\pi(i_{k+1}) < \mu(i_k)$.

Summarizing we have:

$$\mu(i_1) = \mu(1) = \pi(1) < \mu(i_2) < \dots < n > \dots \mu(i_m) = \mu(n) = \pi(n).$$

Moreover, let $\sigma(\pi)$ (briefly σ) denote $(\sigma(j_1), \dots, \sigma(j_r))$ where:

- (1) $\sigma(j_1) = \sigma(1) = \pi(1)$, $\sigma(j_r) = \sigma(n) = \pi(n)$, and
- (2) if $1 < j_k < j_r$, then $\sigma(j_k) = \pi(j_k)$ if and only if $\pi(j_k) \notin \{\mu(i_1), \dots, \mu(i_m)\}$.

We note that the sequence μ can be defined in terms of left-right and right left-maxima. A *left-right maximum* (resp. *right-left maximum*) of a given permutation τ is an entry $\tau(j)$ such that $\tau(j) > \tau(i)$ for each $i < j$ (for each $i > j$). Let $u = (u_{i_1}, u_{i_2}, \dots, u_{i_s})$ be the sequence of the left-right maxima of π with $u_{i_1} = \pi(1) < u_{i_2} < \dots < u_{i_s} = n$, and let $v = (v_{j_1}, v_{j_2}, \dots, v_{j_t})$ be the sequence of the right-left maxima (read from the left) with $v_{j_1} = n > v_{j_2} > \dots > v_{j_t} = \pi(n)$. The sequence μ

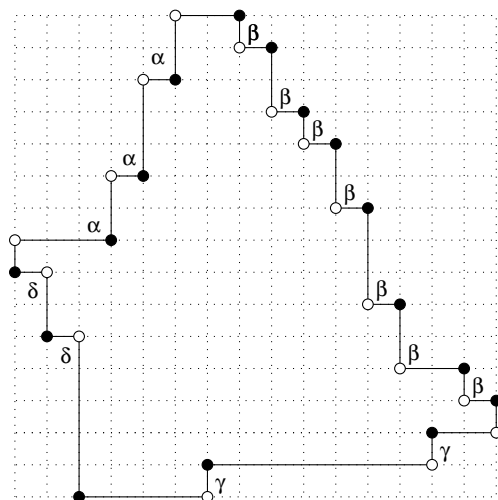

$$\pi_1 = (8, 6, 1, 9, 11, 14, 2, 16, 15, 13, 12, 10, 7, 3, 5, 4)$$

$$\pi_2 = (9, 8, 6, 11, 14, 16, 1, 15, 13, 12, 10, 7, 5, 2, 4, 3)$$

FIGURE 10. A convex permutomino and the associated permutations.

coincides with the sequence obtained by connecting u with v , observing that, clearly, $u_{i_s} = v_{j_1} = n$. In other words it is $\mu = (u_{i_1}, u_{i_2}, \dots, u_{i_s} (= v_{j_1}), v_{j_1}, v_{j_2}, \dots, v_{j_t})$.

Example 1. Consider the convex permutomino of size 16 represented in Figure 10. We have

$$\pi_1 = (8, 6, 1, 9, 11, 14, 2, 16, 15, 13, 12, 10, 7, 3, 5, 4),$$

and we can determine the decomposition of π into the two subsequences μ and σ :

	1	2	3	4	5	6	7	8	9	10	11	12	13	14	15	16
μ	8	-	-	9	11	14	-	16	15	13	12	10	7	-	5	4
σ	8	6	1	-	-	-	2	-	-	-	-	-	-	3	-	4

For the sake of brevity, when there is no possibility of misunderstanding, we use to represent the two sequences omitting the empty spaces, as

$$\mu = (8, 9, 11, 14, 16, 15, 13, 12, 10, 7, 5, 4), \quad \sigma = (8, 6, 1, 2, 3, 4).$$

While μ is upper unimodal by definition, here σ turns out to be lower unimodal. In fact, from the characterization given in Proposition 3 we have that

Proposition 4. *If π is associated with a convex permutomino then the sequence σ is lower unimodal.*

In this case, similarly to the sequence μ , also the sequence σ can be defined in terms of left-right and right-left minima. A *left-right minimum* (resp. *right-left minimum*) of a given permutation τ is an entry $\tau(j)$ such that $\tau(j) < \tau(i)$ for each $i < j$ (for each $i > j$). If σ is lower unimodal, then it is easily seen to be the sequence of the left-right minima followed by the sequence of the right-left minima (read from the left), recalling that the entry 1 is both a left-right minimum and a right-left minimum.

The conclusion of Proposition 4 is a necessary condition for a permutation π to be associated with a convex permutomino, but it is not sufficient. For instance, if we consider the permutation $\pi = (5, 9, 8, 7, 6, 3, 1, 2, 4)$, then $\mu = (5, 9, 8, 7, 6, 4)$, and $\sigma = (5, 3, 1, 2, 4)$ is lower unimodal, but as shown in Figure 11 (a) there is no convex permutomino associated with π . In fact, any convex permutomino associated with such a permutation has a β point below the diagonal $x+y = 10$ and, correspondingly, a δ point above this diagonal. Thus the β and the δ paths cross themselves.

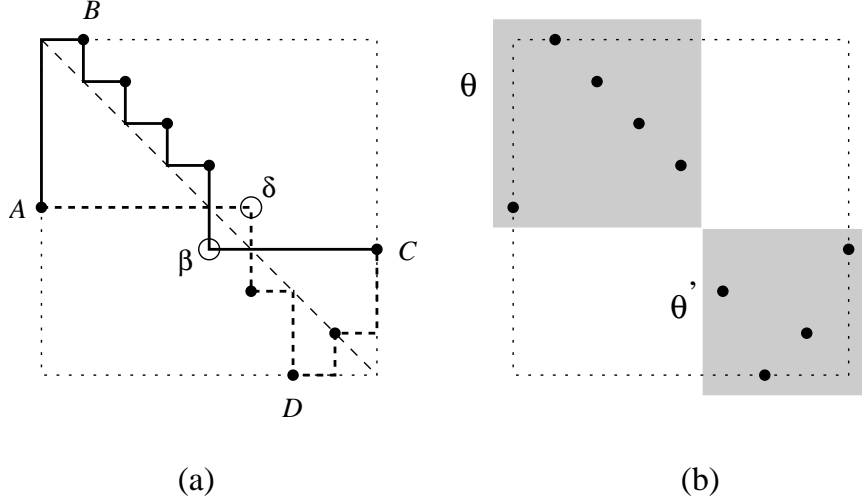

FIGURE 11. (a) there is no convex permutomino associated with $\pi = (5, 9, 8, 7, 6, 3, 1, 2, 4)$, since σ is lower unimodal but the β path passes below the diagonal $x + y = 10$. The β point below the diagonal and the corresponding δ point above the diagonal are encircled. (b) The permutation $\pi = (5, 9, 8, 7, 6, 3, 1, 2, 4)$ is the direct difference $\pi = (1, 5, 4, 3, 2) \ominus (3, 2, 1, 4)$.

In order to give a necessary and sufficient condition for a permutation π to be in $\tilde{\mathcal{C}}_n$, let us recall that, given two permutations $\theta = (\theta_1, \dots, \theta_m) \in \mathcal{S}_m$ and $\theta' = (\theta'_1, \dots, \theta'_{m'}) \in \mathcal{S}_{m'}$, their *direct difference* $\theta \ominus \theta'$ is a permutation of $\mathcal{S}_{m+m'}$ defined as

$$(\theta_1 + m', \dots, \theta_m + m', \theta'_1, \dots, \theta'_{m'}).$$

A pictorial description is given in Figure 11 (b), where $\theta = (1, 5, 4, 3, 2)$, $\theta' = (3, 2, 1, 4)$, and their direct difference is $\theta \ominus \theta' = (5, 9, 8, 7, 6, 3, 1, 2, 4)$.

Finally the following characterization holds.

Theorem 1. *Let $\pi \in \mathcal{S}_n$ be a permutation. Then $\pi \in \tilde{\mathcal{C}}_n$ if and only if:*

- (1) σ is lower unimodal, and
- (2) there are no two permutations, $\theta \in \theta_m$, and $\theta' \in \theta'_{m'}$, such that $m + m' = n$, and $\pi = \theta \ominus \theta'$.

(Proof.) Before starting, we need to observe that in a convex permutomino all the α and γ points belong to the permutation π_1 , thus by **(z1)** they can also lie on the diagonal $x = y$; on the contrary, the β and δ points belong to π_2 , then by **(z2)** all the β (resp. δ) points must remain strictly above (resp. below) the diagonal $x + y = n + 1$.

(\implies) By Proposition 4 we have that σ is lower unimodal. Then, we have to prove that π may not be decomposed into the direct difference of two permutations, $\pi = \theta \ominus \theta'$.

If $\pi(1) < \pi(n)$ the property is straightforward. Let us consider the case $\pi(1) > \pi(n)$, and assume that $\pi = \theta \ominus \theta'$ for some permutations θ and θ' . We will prove that if the vertices of polygon P define the permutation π , then the boundary of P crosses itself, hence P is not a permutomino.

Let us assume that P is a convex permutomino associated with $\pi = \theta \ominus \theta'$. We start by observing that the β and the δ paths of P may not be empty. In fact, if the β path is empty, then $\pi(n) = n > \pi(1)$, against the hypothesis. Similarly, if the δ path is empty, then $\pi(1) = 1 < \pi(n)$. Essentially for the same reason, both θ and θ' must have more than one element.

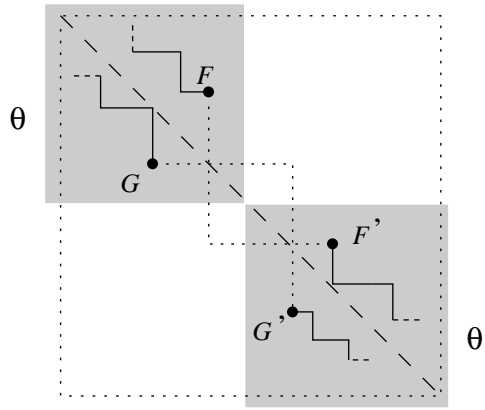

FIGURE 12. If $\pi = \theta \ominus \theta'$ then the boundary of every polygon associated with π crosses itself.

As we observed, the points of θ (resp. θ') in the β path of P , are placed strictly above the diagonal $x + y = n + 1$. Let F (resp. F') be the rightmost (resp. leftmost) of these points. Similarly, there must be at least one point of θ (resp. θ') in the δ path of P , placed strictly below the diagonal $x + y = n + 1$. Let G (resp. G') be the rightmost (resp. leftmost) of these points. The situation is schematically sketched in Figure 12.

Since F and F' are consecutive points in the β path of P , they must be connected by means of a path that goes down and then right, and, similarly, since G' and G are two consecutive points in the δ path, they must be connected by means of a path that goes up and then left. These two paths necessarily cross in at least two points, and their intersections must be on the diagonal $x + y = n + 1$.

(\impliedby) Clearly condition 2. implies that $\pi(1) < n$ and $\pi(n) > 1$, which are necessary conditions for $\pi \in \tilde{\mathcal{C}}_n$. We start building up a polygon P such that $\pi_1(P) = P$, and then prove that P is a permutomino. As usual, let us consider the points

$$A = (1, \pi(1)), \quad B = (\pi^{-1}(n), n), \quad C = (n, \pi(n)), \quad D = (\pi^{-1}(1), 1).$$

The α path of P goes from A to B , and it is constructed connecting the points of μ increasing sequence; more formally, if $\mu(i_l)$ and $\mu(i_{l+1})$ are two consecutive points of μ , with $\mu(i_l) < \mu(i_{l+1}) \leq n$, we connect them by means of a path

$$1^{\mu(i_{l+1})-\mu(i_l)} 0^{i_{l+1}-i_l},$$

(where 1 denotes the vertical, and 0 the horizontal unit step). Similarly we construct the β path, from B to C , the γ path from C to D , and the δ path from D to A .

Since the subsequence σ is lower unimodal the obtained polygon is convex (see Figure 13).

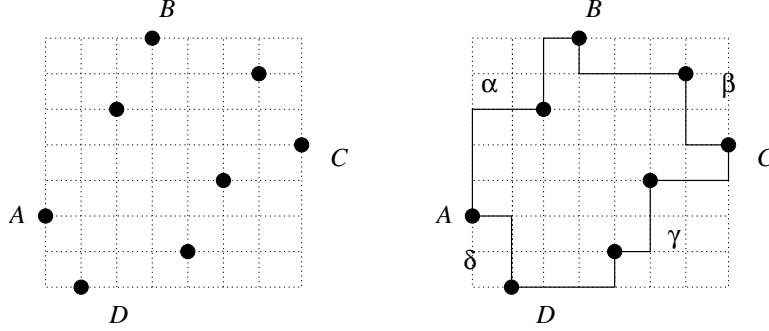

FIGURE 13. Given the permutation $\pi = (3, 1, 6, 8, 2, 4, 7, 5)$ satisfying conditions 1. and 2., we construct the α , β , γ , and δ paths.

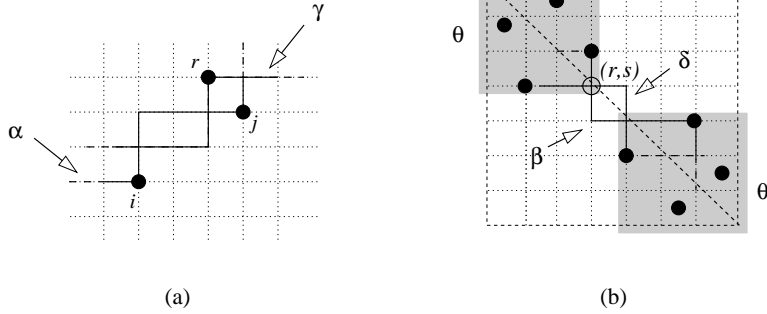

FIGURE 14. (a) The α path and the γ path may not cross; (b) The β path and the δ path may not cross.

Now we must prove that the four paths we have defined may not cross themselves. First we show that the α path and the γ path may not cross. In fact, if this happened, there would be a point $(r, \pi(r))$ in the path γ , and two points $(i, \pi(i))$ and $(j, \pi(j))$ in the path α , such that $i < r < j$, and $\pi(i) < \pi(r) > \pi(j)$ (see Figure 14 (a)). In this case, according to the definition, $\pi(r)$ should belong to μ , and then $(r, \pi(r))$ should be in the path α , and not in γ .

Finally we prove that the paths β and δ may not cross. In fact, if they cross, their intersection should necessarily be on the diagonal $x + y = n + 1$; if (r, s) is the intersection point having minimum abscissa, then the reader can easily check, by considering the various possibilities, that the points $(i, \pi(i))$ of π satisfy:

$$i \leq r \quad \text{if and only if} \quad \pi(i) \geq s$$

(see Figure 14 (b)). Therefore, setting

$$\theta = \{(i, \pi(i) - s + 1) : i \leq r\}$$

we have that θ is a permutation of \mathcal{S}_r , and letting

$$\theta' = \{(i, \pi(i)) : i > r\}$$

we see that $\pi = \theta \ominus \theta'$, against the hypothesis. \square

There is an interesting refinement of the previous general theorem, which applies to a particular subset of the permutations of \mathcal{S}_n .

Corollary 1. Let $\pi \in \mathcal{S}_n$, such that $\pi(1) < \pi(n)$. Then $\pi \in \tilde{\mathcal{C}}_n$ if and only if σ is lower unimodal.

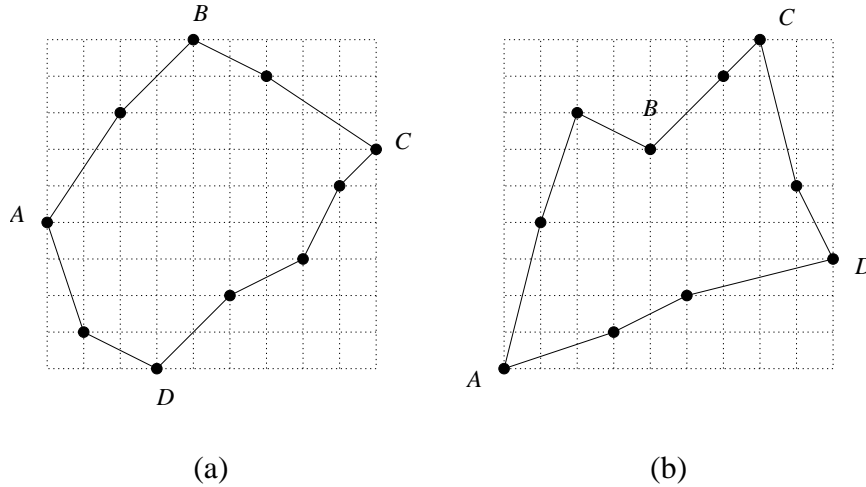

FIGURE 15. (a) a square permutation and the associated 4-face polygon; (b) a 4 face polygon defined by a non square permutation.

At the end of this section we would like to point out an interesting connection between the permutations associated with convex permutominoes and another kind of combinatorial objects treated in some recent works. We are referring to the so called *k-faces permutation polygons* defined by T. Mansour and S. Severini [20]. In order to construct a polygon from a given permutation π in an unambiguous way, they find the set of left-right minima and the set of right-left minima. An entry which is neither a left-right minimum nor a right-left minimum is said to be a *source*, together with the first and the last entry (which are also a left-right minimum and a right-left minimum, respectively). Finally, two entries of π are connected with an edge if they are two consecutive left-right minima or right-left minima or sources. A maximal path of increasing or decreasing edges defines a *face*. If the obtained polygon has k faces, than it is said to be a *k-faces* polygon. A permutation is said to be *square* if the sequence of the sources lies in at most two faces. The set of the square permutations of length n is denoted by \mathcal{Q}_n . We note that a square permutation has at most four faces, but the inverse statement does not hold: the permutation $(1, 5, 8, 2, 7, 3, 9, 10, 6, 4)$ has four faces and it is not square. Figure 15 depicts an example.

Connecting all pairs of consecutive points of the sequences μ and σ we obtain a polygon which may not coincide with the polygon obtained from the definition of Mansour and Severini, as the reader can easily check with the permutation $(1, 2, 4, 3)$. It is however simple to state the following

Proposition 5. *Given a permutation $\pi \in \mathcal{S}_n$, then $\pi \in \mathcal{Q}_n$ if and only if $\sigma(\pi)$ is lower unimodal.*

We point out that the square permutations coincide with the of the *convex permutations*, introduced by Waton [23]. In his PhD thesis the author characterizes the convex permutations in terms of forbidden patterns. More precisely, he proves

that the convex permutations are all the permutations avoiding the following sixteen patterns of length five:

$$\{52341, 52314, 51342, 51324, 42351, 42315, 41352, 41325, \\ 25341, 25314, 15342, 15324, 24351, 24315, 14352, 14325\}.$$

All the relations between \mathcal{Q}_n , \mathcal{C}_n and \mathcal{C}'_n are exploited in the next section, where, in particular, we prove that, given a permutation π , then $\pi \in \mathcal{Q}_n$ if and only if $\pi \in \mathcal{C}_n \cup \mathcal{C}'_n$.

Mansour and Severini [20] (and independently Waton [23]) prove that the number Q_{n+1} of square permutation of size $n + 1$ is

$$(6) \quad Q_{n+1} = 2(n+3)4^{n-2} - 4(2n-3) \binom{2(n-2)}{n-2},$$

defining the sequence (A128652 [21])

$$1, 2, 6, 24, 104, 464, 2088, \dots$$

3.3. The relation between the number of permutations and the number convex permutominoes. Let $\pi \in \tilde{\mathcal{C}}_n$, and μ and σ defined as above. Let $\mathcal{F}(\pi)$ (briefly \mathcal{F}) denote the set of fixed points of π lying in the increasing part of the sequence μ and which are different from 1 and n . We call the points in \mathcal{F} the *free fixed points* of π .

For instance, concerning the permutation $\pi = (2, 1, 3, 4, 7, 6, 5)$ we have $\mu = (2, 3, 4, 7, 6, 5)$, $\sigma = (2, 1, 5)$, and $\mathcal{F}(\pi) = \{3, 4\}$; here 6 is a fixed point of π but it is not on the increasing sequence of μ , then it is not free. By definition, a permutation in $\tilde{\mathcal{C}}_n$ can have no free fixed points (e.g., the permutation associated with the permutomino in Figure 10), and at most $n - 2$ free fixed points (as the identity $(1, \dots, n)$).

Theorem 2. *Let $\pi \in \tilde{\mathcal{C}}_n$, and let $\mathcal{F}(\pi)$ be the set of free fixed points of π . Then we have:*

$$|[\pi]| = 2^{|\mathcal{F}(\pi)|}.$$

(Proof.) Since $\pi \in \tilde{\mathcal{C}}_n$ there exists a permutomino P associated with π . If we look at the permutation matrix defined by the reentrant points of P , we see that all the free fixed points of π can be only of type α or γ , while the type of all the other reentrant points of π is established. It is easy to check that in any way we set the typology of the free fixed points in α or γ we obtain, starting from the matrix of P , a permutation matrix which defines a convex permutomino associated with π , and in this way we get all the convex permutominoes associated with π . \square

Applying Theorem 2 we have that the number of convex permutominoes associated with $\pi = (2, 1, 3, 4, 7, 6, 5)$ is $2^2 = 4$, as shown in Figure 16. Moreover, Theorem 2 leads to an interesting property.

Proposition 6. *Let $\pi \in \tilde{\mathcal{C}}_n$, with $\pi(1) > \pi(n)$. Then there is only one convex permutomino associated with π , i.e., $|\pi| = 1$.*

(Proof.) If $\pi(1) > \pi(n)$ then all the points in the increasing part of μ are strictly above the diagonal $x = y$, then π cannot have free fixed points. The thesis is then straightforward. \square

Let us now introduce the sets $\tilde{\mathcal{C}}_{n,k}$ of permutations having exactly k free fixed points, with $0 \leq k \leq n - 2$. We easily derive the following relations:

$$(7) \quad \tilde{\mathcal{C}}_n = \sum_{k=0}^{n-2} |\tilde{\mathcal{C}}_{n,k}| \quad C_n = \sum_{k=0}^{n-2} 2^k |\tilde{\mathcal{C}}_{n,k}|.$$

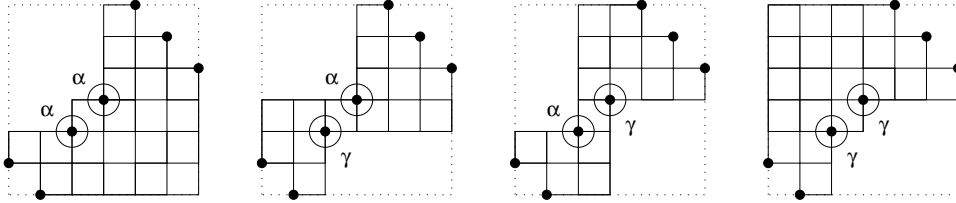

FIGURE 16. The four convex permutominoes associated with the permutation $\pi = (2, 1, 3, 4, 7, 6, 5)$. The two free fixed points are encircled.

4. THE CARDINALITY OF $\tilde{\mathcal{C}}_n$

In order to find a formula to express $\tilde{\mathcal{C}}_n$, it is now sufficient to count how many permutations of \mathcal{Q}_n can be decomposed into the direct difference of other permutations. We say that a square permutation is *indecomposable* if it is not the direct difference of two permutations. For any $k \geq 2$, let

$$\mathcal{B}_{n,k} = \{ \pi \in \mathcal{Q}_n : \pi = \theta_1 \ominus \dots \ominus \theta_k, \theta_i \text{ indecomposable}, 1 \leq i \leq k \}$$

be the set of square permutations which are direct difference of exactly k indecomposable permutations, and

$$\mathcal{B}_n = \bigcup_{k \geq 2} \mathcal{B}_{n,k}.$$

For any $n, k \geq 2$, let $\mathcal{T}_{n,k}$ be the class of the sequences (P_1, \dots, P_k) such that:

- i: P_1 and P_k are (possibly empty) directed convex permutominoes,
- ii: P_2, \dots, P_{k-1} are (possibly empty) parallelogram permutominoes,

and such that the sum of the dimensions of P_1, \dots, P_k is equal to n .

Proposition 7. *There is a bijective correspondence between the elements of $\mathcal{B}_{n,k}$ and the elements of $\mathcal{T}_{n,k}$, so that the two classes have the same cardinality.*

(Proof.) Let us consider $(P_1, \dots, P_k) \in \mathcal{T}_{n,k}$, we construct the corresponding permutation $\pi = \delta_1 \ominus \dots \ominus \delta_k$ as follows. For any $1 \leq i \leq k$, if P_i is the empty permutomino, then $\delta_i = (1)$, otherwise:

- i: for all i with $1 \leq i \leq k-1$, δ_i is the reversal of $\pi_2(P_i)$ (i.e., the permutation π_1 associated with the symmetric permutomino of P_i with respect to the y -axis).
- ii: δ_k is the complement of $\pi_2(P_k)$ (i.e., it is the permutation π_1 associated with the symmetric permutomino of P_k with respect to the x -axis).

For example, starting from the sequence of permutominoes in Figure 17 we obtain the following permutations: $\delta_1 = (2, 1, 4, 5, 3)$ is obtained from the permutomino P_1 such that $\pi_2(P_1) = (3, 5, 4, 1, 2)$; $\delta_2 = (1)$ is obtained from the empty permutomino P_2 ; $\delta_3 = (1, 2)$ is obtained from P_3 ; $\delta_4 = (3, 1, 5, 4, 2)$ is obtained from the permutomino P_4 such that $\pi_2(P_4) = (2, 4, 5, 1, 3)$. Moreover, $\delta_5 = (3, 1, 6, 5, 2, 4)$ is the complement of $\tau = (4, 6, 1, 2, 5, 3)$ which is such that $\pi_2(P_5) = \tau$. Then, as showed in Figure 18, we obtain the permutation $\pi = \delta_1 \ominus \delta_2 \ominus \delta_4 \ominus \delta_4 \ominus \delta_5$,

$$\pi = (16, 15, 18, 19, 17, 14, 12, 13, 9, 7, 11, 10, 8, 3, 1, 6, 5, 2, 4)$$

We note that the points in the increasing part of $\mu(\pi)$ are precisely the points of the increasing part of $\mu(\delta_1)$; the points in the increasing part of $\sigma(\pi)$ are the points of the increasing part of $\sigma(\delta_k)$; the points in the decreasing part of $\mu(\pi)$ are given by the sequence of points of the decreasing parts of $\mu(\delta_1), \dots, \mu(\delta_k)$; finally, the

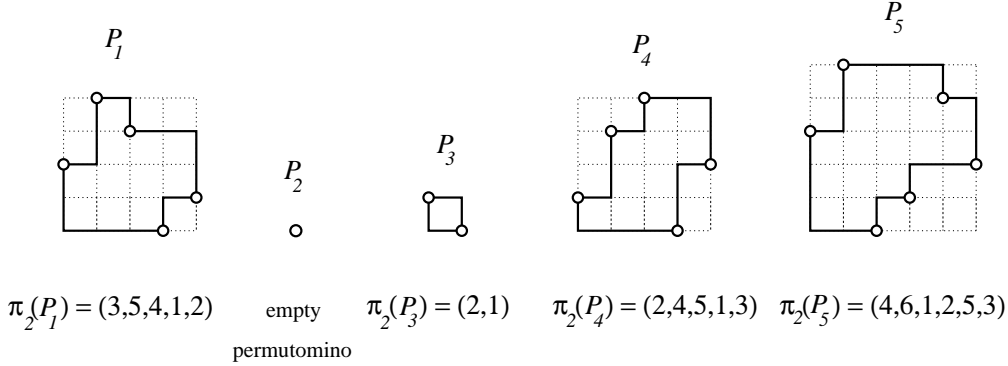

FIGURE 17. An element of $\mathcal{T}_{19,5}$, constituted of a sequence of five permutominoes, and the associated permutations.

points in the decreasing part of $\sigma(\pi)$ are given by the sequence of the points of the decreasing parts of $\sigma(\delta_1), \dots, \sigma(\delta_k)$. Then, we have that $\pi \in \mathcal{Q}_n$ and then $\pi \in \mathcal{B}_{n,k}$.

Conversely, let $\pi \in \mathcal{B}_{n,k}$, with $\pi = \delta_1 \ominus \dots \ominus \delta_k$. By the previous considerations we have that $\pi \in \mathcal{Q}_n$, and then it is clear that, for each component δ_i , the sequence $\mu(\delta_i)$ is upper unimodal, and $\sigma(\delta_i)$ is lower unimodal.

If δ_i is the one element permutation, then it is associated with the empty permutomino. Otherwise, if a permutation δ_i is indecomposable and has dimension greater than 1 it is clearly associated with a polygon with exactly one side for every abscissa and ordinate and with the border which does not intersect itself. These two conditions are sufficient to state that δ_i is associated with a convex permutomino, and in particular the reader can easily observe the following properties, due to its the indecomposability:

- (1) there is exactly one directed convex permutomino P_1 corresponding to δ_1 , and it is the reflection according to the y -axis of a permutomino associated with δ_1 ;
- (2) for any $2 \leq i \leq k-1$, there is exactly one parallelogram permutomino P_i corresponding to δ_i , and it is the reflection according to the y -axis of a permutomino associated with δ_i ;
- (3) there is exactly one directed convex permutomino P_k corresponding to δ_k , and it is the reflection according to the x -axis of a permutomino associated with δ_k .

We have thus the sequence $(P_1, \dots, P_k) \in \mathcal{T}_{n,k}$. \square

If we denote by B_n (resp. $B_{n,k}$) the cardinality of \mathcal{B}_n (resp. $\mathcal{B}_{n,k}$), by Proposition 5 we have

$$\tilde{C}_n = Q_n - B_n.$$

Let us pass to generating functions, denoting by:

- (1) $P(x)$ (resp. $D(x)$) the generating function of parallelogram permutominoes (resp. $P(x)$), hence

$$P(x) = \frac{1 - \sqrt{1 - 4x}}{2} = x + x^2 + 2x^3 + 5x^4 + 14x^5 + \dots$$

$$D(x) = \frac{x}{2} \left(\frac{1}{\sqrt{1 - 4x}} + 1 \right) = x + x^2 + 3x^3 + 10x^4 + 35x^5 + \dots;$$

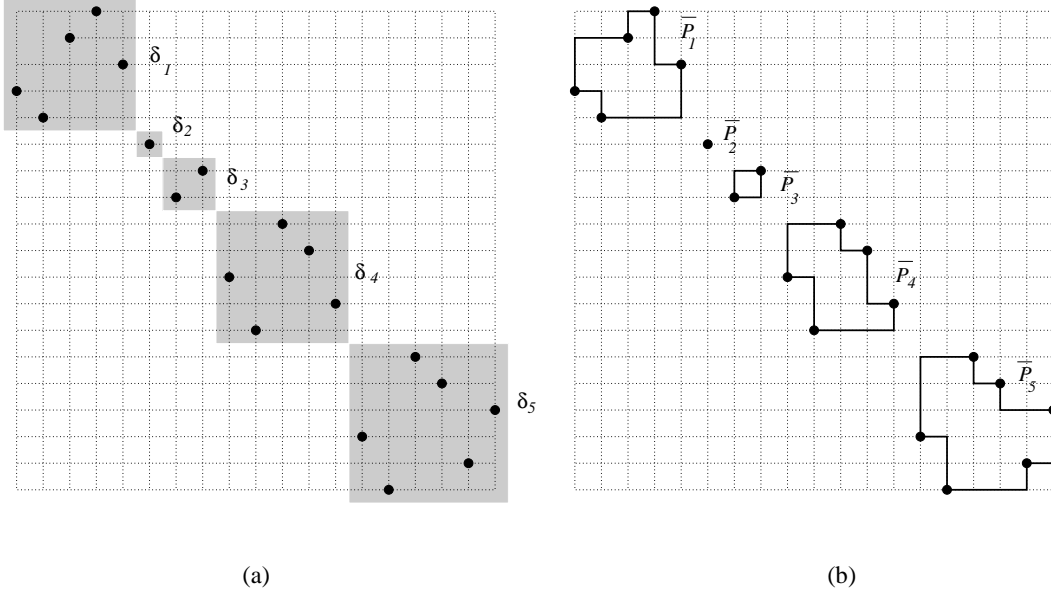

FIGURE 18. (a) a square permutation which can be decomposed into the direct difference of five indecomposable permutations; (b) the five permutominoes associated with them. For each permutomino P_i , we denote by \bar{P}_i the corresponding reflected permutomino.

- (2) $B_k(x)$ (resp. $B(x)$) the generating function of the numbers $\{B_{k,n}\}_{n \geq 0}$, $k \geq 2$ (resp. $\{B_n\}_{n \geq 0}$).

Due to Proposition 7, for any $k \geq 2$, we have that $B_k(x) = D^2(x)P^{k-2}(x)$ and then

$$B(x) = \sum_{k \geq 0} D^2(x)P^{k-2}(x) = \frac{D^2(x)}{1 - P(x)} = \frac{1}{2} \left(\frac{x^2}{1 - 4x} + \frac{x^2}{\sqrt{1 - 4x}} \right).$$

Therefore

$$B_{n+2} = \frac{1}{2} \left(4^n + \binom{2n}{n} \right) = \sum_{i=0}^n \binom{2n}{i}.$$

Now it is easy to determine the cardinality of $\tilde{\mathcal{C}}_n$. For simplicity of notation we will express most of the following formulas in terms of $n + 1$ instead of n .

Proposition 8. The number of permutations of $\tilde{\mathcal{C}}_{n+1}$ is

$$(8) \quad 2(n+2)4^{n-2} - \frac{n}{4} \left(\frac{3-4n}{1-2n} \right) \binom{2n}{n}, \quad n \geq 1.$$

(Proof.) In fact, for any $n \geq 2$, we have $\tilde{\mathcal{C}}_n = Q_n - B_n$, then the result is straightforward. \square

For the sake of completeness, in Table 1 we list the first terms of the sequences involved in the preceding formulas.

In ending the paper we would like to point out some other results that directly come out from the one stated in Proposition 8. First we observe that:

- i:** the number of permutations $\pi \in \tilde{\mathcal{C}}_n$ for which $\pi(1) < \pi(n)$ is equal to $\frac{1}{2}Q_n$,

sequence	1	2	3	4	5	6	7	8	...
Q_n	1	2	6	24	104	464	2088	9392	...
B_n		1	3	11	42	163	638	2510	...
\tilde{C}_n	1	1	3	13	62	301	1450	6882	...

TABLE 1. The first terms of the sequences Q_n , B_n , \tilde{C}_n , starting with $n = 1$.

ii: the number of of permutations for which $\pi(1) > \pi(n)$ is equal to

$$\frac{1}{2}Q_n - B_n = \tilde{C}_n - \frac{1}{2}Q_n,$$

and the $(n + 1)$ th term of this difference is equal to

$$(9) \quad (n + 1)4^{n-2} - \frac{n}{2} \binom{2n+1}{n-1},$$

whose first terms are 1, 10, 69, 406, 2186, 11124, \dots , (sequence A038806 [21]).

Moreover, it is also possible to consider the set $\tilde{C}_n \cap \tilde{C}'_n$, i.e., the set of the permutations π for which there is at least one convex permutomino P such that $\pi_1(P) = \pi$ and one convex permutomino P' such that $\pi_2(P') = \pi$. For instance, we have:

$$\tilde{C}_3 \cap \tilde{C}'_3 = \emptyset,$$

$$\tilde{C}_4 \cap \tilde{C}'_4 = \{(2, 4, 1, 3), (3, 1, 4, 2)\}.$$

We start by recalling that $\pi \in \tilde{C}_n$ if and only if $\pi^R \in \tilde{C}'_n$.

Proposition 9. A permutation $\pi \in \mathcal{Q}_n$ if and only if $\pi \in \tilde{C}_n \cup \tilde{C}'_n$.

(Proof.) (\Leftarrow) If π is a square permutation but it is not in \tilde{C}_n , then necessarily $\pi(1) > \pi(n)$. Hence, if we consider π^R , we have $\pi^R(1) < \pi^R(n)$, and $\pi^R \in \tilde{C}_n$, then $\pi \in \tilde{C}'_n$.

(\Rightarrow) Trivial. \square

Finally, since $|\tilde{C}'_n| = |\tilde{C}_n|$, and $Q_n = 2\tilde{C}_n - |\tilde{C}_n \cap \tilde{C}'_n|$, we can state the following.

Proposition 10. For any $n \geq 2$, we have

$$(10) \quad |\tilde{C}_n \cap \tilde{C}'_n| = \tilde{C}_n - B_n = Q_n - 2B_n.$$

The reader can easily recognize that the numbers defined by (10) are the double of the ones expressed by the formula in (9), so that

$$(11) \quad |\tilde{C}_{n+1} \cap \tilde{C}'_{n+1}| = 2(n + 1)4^{n-2} - \binom{2n-1}{n-1}.$$

5. FURTHER WORK

Here we outline the main open problems and research lines on the class of permutominoes.

- (1) It would be natural to look for a combinatorial proof of the formula (4) for the number of convex permutominoes and (8) for the number of permutations associated with convex permutominoes. These proofs could be obtained using the matrix characterization for convex permutominoes provided in Section 3.1.
- (2) The main results of the paper have been obtained in an analytical way. In particular from (4) and (8) we have a direct relation between convex permutominoes and permutations, obtaining

$$(12) \quad C_{n+2} = \tilde{C}_{n+2} + \frac{1}{2} \left(4^n - \binom{2n}{n} \right),$$

which requires a combinatorial explanation. In particular, recalling that

$$C_n = \sum_{\pi \in \tilde{C}_n} |\pi|,$$

the right term of (12) is the number of convex permutominoes which are determined by the permutations having at least one free fixed point.

Moreover, from (8) and (12) we get that

$$Q_{n+2} = C_{n+2} + \binom{2n}{n},$$

and also this identity cannot be clearly explained using the combinatorial arguments used in the paper.

From (11) we have that the generating function of the permutations in $\tilde{C}_n \cap \tilde{C}'_n$ is

$$2 \left(\frac{x^2 c(x)}{1 - 4x} \right)^2,$$

where $c(x)$ denotes the generating function of Catalan numbers. While the factor 2 can be easily explained, since for any $\pi \in \tilde{C}_n \cap \tilde{C}'_n$, also $\pi^R \in \tilde{C}_n \cap \tilde{C}'_n$, and clearly $\pi \neq \pi^R$, the convolution of Catalan numbers and the powers of four begs for a combinatorial interpretation.

- (3) We would like to consider the characterization and the enumeration of the permutations associated with other classes of permutominoes, possibly including the class of convex permutominoes. For instance, if we take the class of column convex permutominoes, we observe that Proposition 2 does not hold. In particular, one can see that, if the permutomino is not convex, then the set of reentrant points does not form a permutation matrix (see Figure 19).

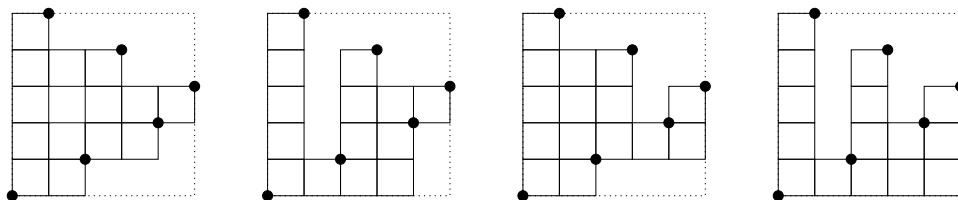

FIGURE 19. The four column convex permutominoes associated with the permutation (1, 6, 2, 5, 3, 4); only the leftmost is convex

Moreover, it might be interesting to determine an extension of Theorem 2 for the class of column convex permutominoes, i.e., to characterize the set

of column convex permutominoes associated with a given permutation. For instance, we observe that while there is one convex permutomino associated with $\pi = (1, 6, 2, 5, 3, 4)$, there are four column convex permutominoes associated with π (see Figure 19).

REFERENCES

- [1] G. Barequet, M. Moffie, A. Rib and G. Rote, Counting Polyominoes on Twisted Cylinders, Proc. of *EuroComb '05, European Conference on Combinatorics, Graph Theory and Applications*, Ed. S. Felsner, *Disc. Math. Theor. Comput. Sci.* Proceedings AE, 369–374.
- [2] D. Beauquier and M. Nivat, Tiling the plane with one tile, Proc. of *6th Annual Symposium on Computational geometry*, Berkeley, CA, ACM press (1990), 128–138.
- [3] P. Boldi, V. Lonati, R. Radicioni and M. Santini, The number of convex permutominoes, Proc. of *LATA 2007, International Conference on Language and Automata Theory and Applications*, Tarragona, Spain, (2007).
- [4] M. Bousquet-Mélou, A method for the enumeration of various classes of column convex polygons, *Discrete Math.* **154** (1996), 1–25.
- [5] M. Bousquet-Mélou and A. J. Guttmann, Enumeration of three dimensional convex polygons, *Ann. Comb.* **1** (1997), 27–53.
- [6] R. Brak, A. J. Guttmann, and I. G. Enting, Exact solution of the row-convex polygon perimeter generating function, *J. Phys. A* **23** (1990), L2319–L2326.
- [7] S. Brlek, G. Labelle and A. Lacasse, A Note on a Result of Daurat and Nivat, *Lecture Notes in Comput. Sci.*, Springer Berlin/Heidelberg, Vol. 3572 (2005), 189–198.
- [8] S. J. Chang, and K. Y. Lin, Rigorous results for the number of convex polygons on the square and honeycomb lattices, *J. Phys. A* **21** (1988), 2635–2642.
- [9] J. H. Conway and J. C. Lagarias, Tiling with polyominoes and combinatorial group theory, *J. Combin. Theory Ser. A* **53** (1990), 183–208.
- [10] A. Daurat and M. Nivat, Salient and reentrant points of discrete sets, *Discrete Appl. Math.* **151** (2005), 106–121.
- [11] M. Delest and X. G. Viennot, Algebraic languages and polyominoes enumeration, *Theoret. Comput. Sci.* **34** (1984), 169–206.
- [12] A. Del Lungo, E. Duchi, A. Frosini and S. Rinaldi, On the generation and enumeration of some classes of convex polyominoes, *Electron. J. Combin.* **11** (2004), #R60.
- [13] F. Disanto, A. Frosini, R. Pinzani and S. Rinaldi, A closed formula for the number of convex permutominoes, *ArXiv Mathematics e-prints* math/0702550 (2007).
- [14] I. Fanti, A. Frosini, E. Grazzini, R. Pinzani and S. Rinaldi, polyominoes determined by permutations, (*submitted*).
- [15] M. Gardner, Mathematical games, *Scientific American* (1958), Sept. 182–192, Nov. 136–142.
- [16] S. W. Golomb, *Polyominoes: Puzzles, Patterns, Problems, and Packings*, Princeton Academic Press, 1996.
- [17] S. W. Golomb, Checker boards and polyominoes, *Amer. Math. Monthly* **61** (1954), 675–682.
- [18] I. Jensen and A. J. Guttmann, Statistics of lattice animals (polyominoes) and polygons, *J. Phys. A* **33** (2000), 257–263.
- [19] F. Incitti, Permutation diagrams, fixed points and Kazhdan-Lusztig R -polynomials, *Ann. Comb.* **10** (2006), 369–387.
- [20] T. Mansour and S. Severini, Grid polygons from permutations and their enumeration by the kernel method, *ArXiv Mathematics e-prints* math/0603225 (2006).
- [21] N. J. A. Sloane, The On-Line Encyclopedia of Integer Sequences, <http://www.research.att.com/~njas/sequences/>
- [22] R. P. Stanley, *Enumerative Combinatorics*, Vol. 2, Cambridge University Press, 1999.
- [23] S. Waton, On Permutation Classes Generated by Token Passing Networks, Gridding Matrices and Pictures: Three Flavours of Involvement, *PhD Thesis*, University of St Andrews (2007).

2000 *Mathematics Subject Classification*: Primary 05A15; Secondary 05A05.

Keywords: permutominoes, polyominoes.

(Concerned with sequences A005436, A000984, A000108, A126020, A122122, A128652 and A038806)

Antonio Bernini, Renzo Pinzani:

UNIVERSITÀ DI FIRENZE, DIPARTIMENTO DI SISTEMI E INFORMATICA
VIALE MORGAGNI 65, 50134 FIRENZE, ITALY ([bernini](mailto:bernini@dsi.unifi.it), pinzani@dsi.unifi.it).

Filippo Disanto, Simone Rinaldi:

UNIVERSITÀ DI SIENA, DIPARTIMENTO DI SCIENZE MATEMATICHE E INFORMATICHE
PIAN DEI MANTELLINI 44, 53100 SIENA, ITALY (rinaldi@unisi.it).